

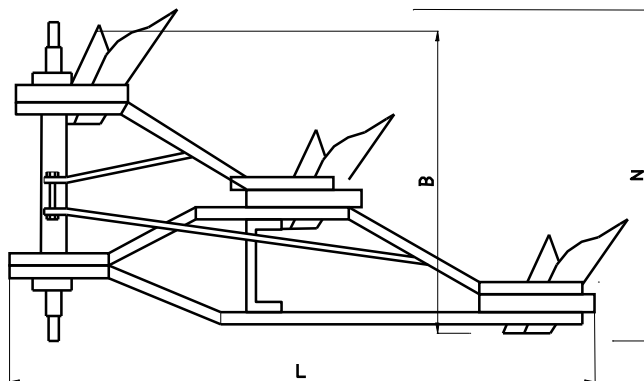

## FIELDKING MOUNTED M.B. PLOUGH



### **BENEFITS :**

- It can handle the toughest ploughing job with outstanding penetration performance.
- It is designed to work in all types of soil for basic functions such as soil breaking, soil raising and soil turning.
- It can be used in stony & rooted soils.

### **FEATURES :**

- The under-frame and unit-to-unit clearance are adequate to cope with trashy conditions.
- Adding an extra furrow or repositioning units to allow for extra clearance is quick and easy.
- The plough has special wear-resistant steel bottoms with bar points for toughest ploughing jobs.
- Bar point bottoms ensure longer life as they can be extended or reversed and re-used till the last possible length.

### **SPECIFICATIONS :**

CODE	MBP-001A	MBP-001B
SIZE	2 FURROW	3 FURROW
FRAME	65x65x8 mm Box & 50 mm Round	65x65x8 mm Box & 50 mm Round
TYNE	36 mm Profile Cut Single Piece	36 mm Profile Cut Single Piece
LENGTH (L)	1300 mm	1880 mm
WIDTH (N)	738 mm	738 mm
HEIGHT	1066 mm	1066 mm
BLADE	10 mm	10 mm
MOULD BOARD	8 mm	8 mm
SHOVEL	40x25 mm Bar (EN – 42 Forged)	40x25 mm Bar (EN – 42 Forged)
3 POINT LINKAGE	65x16 mm Flat & 31 mm Square	65x16 mm Flat & 31 mm Square
CLAMP	125x50 mm	125x50 mm
WIDTH OF CUT (B)	610mm (max)	910mm (max)
DEPTH OF CUT	350mm (max)	350mm (max)
WEIGHT	235 Kg. (approx)	350 Kg. (approx)
POWER REQUIRED (HP)	30-40	55-60

\*The weight and working data contained in the present leaflet are supplied for information only and are not binding. Specification and size can be altered as part of ongoing product modification/improvement.

Mfg. By:

**BERI UDYOG PVT. LTD.**

(AN ISO 9001-2000 COMPANY)

PLOT NO.100-101, SECTOR 3, HSIIDC, KARNAL (HARYANA ) INDIA

PH: 00 91 184 2221571/72/73, FAX: 00 91 184 2221574

E-mail: [info@fieldking.com](mailto:info@fieldking.com), Homepage: [www.fieldking.com](http://www.fieldking.com)