

FIELDKING

3 Way Tipping Trailer



➤ [Operator Manual](#) ➤ [Service Manual](#) ➤ [Part Catalogue](#)

CONGRATULATIONS!

You have invested in one of the best implements of its type in the market today.

The care you give your “FIELDKING” implement will greatly determine your satisfaction with its performance and its service life. A careful study of this manual will give you a thorough understanding of your new implement before operating.

If your manual is lost or destroyed, “FIELDKING” will be glad to provide you a new copy. Visit to nearest dealership & get a copy. Most of our manuals can also be downloaded from our website at www.fieldking.com.

As an authorized “FIELDKING” dealer, we stock genuine “FIELDKING” parts which are manufactured with the same precision and skill as our original equipment. Our trained service persons are well informed on methods required to service “FIELDKING” equipments and are ready to help you.

Should you require additional information or assistance, please contact us.

YOUR AUTHORIZED

FIELDKING DEALER

BECAUSE “FIELDKING” MAINTAINS AN ONGOING PROGRAMME OF PRODUCT IMPROVEMENT, WE RESERVE THE RIGHT TO MAKE IMPROVEMENTS IN DESIGN OR CHANGES IN SPECIFICATION WITHOUT INCURRING ANY OBLIGATION TO INSTALL THEM ON UNITS PREVIOUSLY SOLD. BECAUSE OF THE POSSIBILITY THAT SOME PHOTOGRAPHS IN THIS MANUAL WERE TAKEN OF PROTOTYPE MODELS, PRODUCTION MODELS MAY VARY IN SOME DETAIL. IN ADDITION, SOME PHOTOGRAPHS MAY SHOW SHIELDS REMOVED FOR THE PURPOSE OF CLARITY. NEVER OPERATE THIS IMPLEMENT WITHOUT ALL SHIELDS IN PLACE.

TO THE PURCHASER

This manual contains valuable information about your new “FIELDKING” tipping trailer. It has been carefully prepared to give you helpful suggestions for operating, adjusting, servicing and ordering spare parts.

Keep this manual in a convenient place for quick and easy reference. Study it carefully. You have purchased a dependable and sturdy tipping trailer, but only by proper care and operation you can expect to receive the service and long life designed and built into it.

Sometime in the future your tipping trailer may need new parts to replace which are worn out or broken. If so, go to your dealer and provide him equipment’s detail like model and part number.

CUSTOMER INFORMATION

Name _____

Purchased From _____

Date of Purchase _____

Model No. _____

Serial No. _____

PURCHASER / OPERATOR'S RESPONSIBILITY

1. Read and understand the information contained in this manual.
2. Operate, lubricate, assemble and maintain the equipment in accordance with all instructions and safety procedures in this manual.
3. Inspect the equipment and replace or repair any parts that are damaged or worn out which under continued operation would cause damage, wear to other parts, or cause a safety hazard.
4. Return the equipment or parts to the authorized "FIELDKING" dealer from where it was purchased for service or replacement of defective parts that are covered by warranty. (The "FIELDKING" Factory may inspect equipment or parts before warranty claims are honored.)
5. All costs incurred by the dealer for traveling to or transporting the equipment for warranty inspection and claims will be borne by the customer.

INDEX

- 1. TECHNICAL DATA**
 - 1.1 Introduction
 - 1.2 Warranty
 - 1.3 When the warranty becomes void
 - 1.4 Warning
- 2. USAGE INSTRUCTIONS**
 - 2.1 Before use
 - 2.2 Hitching up the trailer
 - 2.3 Unhitching the trailer
 - 2.4 Loading & tipping the trailer
 - 2.5 Towing the trailer
 - 2.6 Safety
- 3. MAINTENANCE**
 - 3.1 Maintenance Instructions
 - 3.2 Storage of machine after work
 - 3.3 Lubrication
- 4. INSTRUCTION FOR DRIVER**
- 5. FIELDKING – 3 WAY TRAILER**
 - 5.1 Introduction
 - 5.2 Maintenance
 - 5.3 Annual Inspection:
- 6. TROUBLE- SHOOTING CHART**
- 7. SPARE PARTS LIST**

CAUTIONS

NOT TO DO



NEVER DRIVE WITH
TRAILER BODY RAISED



DO NOT OVERLOAD



NEVER REACH UNDER
UNPROPPED TRAILER BODY



BEWARE OF
OVERHEAD CABLES

TO DO



ENSURE GROUND IS FIRM &
MANUAL LEVEL BEFORE TIPPING



READ OPERATOR'
BEFORE USE

1. TECHNICAL DATA

1.1 INTRODUCTION

Thank you for purchasing this "FIELDKING" product. It has been designed to give you many years of use. This handbook contains the use and maintenance instructions with a list of the spare parts of the trailer. Regular and satisfactory operation together with economic and long lasting use of the implement depends on the compliance with instructions given in this handbook.

Compliance with the instructions in this handbook is also important since manufacturer declines all and every responsibility for damage to persons or property caused by negligence and failure to comply with these instructions.

1.2 WARRANTY

When the machine is delivered, check that it has not been subjected to damage during transport and that the accessories are in a perfect condition and complete.

Any claims following the receipt of damaged goods shall be presented in writing within 8 days from the receipt of the goods.

The purchaser may only make the claims under warranty when he has complied with the warranty conditions in the supply contract.

1.3 WHEN THE WARRANTY BECOMES VOID

Besides the cases specified in the supply agreement, the warranty shall in any case become void.

1. When the implement has been used beyond the specified power limit like (Tractor Horse Power)
2. When repairs made by the customer without authorization from the manufacturer or owing to installation of spurious spare parts, the machine is subjected to variations and the damage can be ascribed to these variations.
3. When the user has failed to comply with the instructions in this handbook.
4. No warranty will be given if the service is not done on time.

1.4 WARNING

1. Thoroughly read the instruction manual before proceeding with the various operations.
2. Maintain the trailer as per the instructions of this handbook.

The trailer is a road worthy equipment which if not used correctly could endanger the operator or bystanders.

2. USAGE INSTRUCTIONS

The "FIELDKING" tipping trailer has been designed to operate in tandem with tractors capable of safely towing a gross wt. of 3/5/9 ton (As specified on your trailer) fitted with draw-bar & having a hydraulic supply of at least 138 bar (2000 psi) via a trailer tipping pipe with quick connect fittings.

This equipment is designed for transporting & loading materials. Use in any other way is contrary to the intended use.

The manufacturer accepts no liability for damage or injury resulting from misuse. Compliance with the instructions in this manual is essential for safe operations.

2.1 BEFORE USE

1. Check tyre condition & pressure and ensure that all wheel nuts are tight.
2. Check there are no visible hydraulic leaks & that hydraulic hoses are in good condition.
3. Check that there is no other damage to the trailer that could cause a safety risk.
4. Lubricate trailer as in the maintenance section.

2.2 HITCHING UP THE TRAILER

1. Ensure that there are no bystanders in the immediate area.
2. Reverse tractor slowly & squarely up to the trailer so that the trailer drawbar eye fits between clevis of the tractor drawbar.
3. Adjust the trailer drawbar height with the jack if necessary.
4. Secure the trailer with a proper drawbar pin of the correct size for your tractor's drawbar & retain with a lynch pin.
5. Check that that the tractor link arms are fully raised & will not foul the drawbar at any angle. If in doubt remove them.
6. Check that both halves of the connector are free from dirt then connect the hydraulic hose to the tipping pipe connector on the tractor

2.3 UNHITCHING THE TRAILER

1. Select a suitable place on firm level ground.
2. Check that trailer body is fully lowered on to chassis.
3. Lock on hand brakes & choke trailer wheels.
4. Unhitch drawbar.
5. Position hydraulic hoses above the ground, away from dirt.

2.4 LOADING & TIPPING THE TRAILER

1. Ensure load is evenly spread & is not heaped above the top of the sides. Maximum payload is 3,5 or 9 ton (As specified on your trailer) provided the towing tractor has a safe towing capability.

2. Select a firm level place with no overhead power lines or obstructions & ensure there are no bystanders. All unauthorized persons must keep clear of raised loads.
3. Never reach under a raised trailer body.
4. Never drive with the trailer body raised or attempt to facilitate discharge of load by jerking tractor.
5. If tractor fails to tip check that all hydraulic couplings are properly connected & that the tractor has sufficient oil in it. If it still fails to tip the trailer may be overloaded in which case you will need to manually remove some of the load.

2.5 TOWING THE TRAILER

1. Fit front weights to the tractor if needed to maintain good steering control.
2. Do not exceed 30 km/h & reduce speed on slopes & rough grounds.
3. Always engage low gears when going down hills.
4. Always keep tractor in gear & do not coast.
5. Always lock tractor's independent brakes together before traveling on roads.
6. If someone is guiding you while reversing make sure they are always within your sight to avoid them being trapped.

2.6 SAFETY

You are responsible for the safety of both yourself & those around you when using the trailer. Failure to use could result in someone being killed – please observe the safety precautions & ensure that this doesn't happen.

1. Do ensure that every single operator who will use this machine is fully trained in the safe use of it.
2. Do ensure that both tractor & trailer are parked on firm level ground & breaks are applied before tipping.
3. Do ensure that there are no persons in the immediate area of use other than the operator.
4. Do not drive with the trailer body raised, or attempt to facilitate discharge of load by jerking tractor.
5. Do not reach under the raised trailer body for any reason unless it has been safely choked first.
6. Do not allow passengers on tractor or trailer
7. Do not climb on trailer when raised.
8. Do not overload. Maximum payload is 3/5/9 Ton (As specified on your trailer) provided the towing tractor has a safe towing capability.
9. Do not use trailer unless you have first checked that it is in safe working order.

10. Do ensure that the trailer is parked on level ground with engine stopped & hand-break applied before dismounting from tractor.
11. Do not unhitch the trailer when loaded.
12. Do ensure that all pressure is released from hydraulic system & trailer body is resting on chassis before transporting, parking or maintaining trailer.
13. Do not modify this trailer in any way as this may impair its safety.
14. Do not make any improvisation repairs to the trailer or hydraulic system.
15. The hydraulic operates at very high pressure. Do always wear hand & eye protection and use a piece of cardboard to identify where a hydraulic leak is coming from. If high pressure fluid pierces your skin obtain hospital treatment.
16. Do not attempt to repair tyres unless you are fully competent. Do not exceed maximum pressure marked on tyres. Compressed air in tyres can cause fatal explosions if proper procedures are not followed.

3. MAINTENANCE

3.1 MAINTENANCE INSTRUCTIONS

All maintenance should be carried out on firm level ground with tractor switched off, hand-brakes applied & trailer body fully lowered. Never look under a raised trailer body unless necessary & the body is securely held up.

Daily Checks:

1. Check tyres pressure.
2. There should be no leakage of hydraulic oil.

Monthly Checks :

1. Check wheel nuts are tight.
2. Lubricate all jack & all pivot points.
3. Inspect all hydraulic hoses & chassis for any damage or signs of cracking.

3.2 STORAGE OF MACHINE AFTER WORK

1. Wash the trailer after use.
2. Replace the worn out nuts & bolts.
3. If trailer has to remain unused for long time then clean it & apply a layer of used oil and cover it for rust prevention.

3.3 LUBRICATION

Check the grease in your hubs once a year. In most instances, if a good lubricant is used and the lubricants levels are maintained, it may not be necessary. However, should the grease appear to be contaminated or broken down, remove all the old grease from the bearings and hubs and completely re pack.

“These steps will enhance the life of your trailer.”

4. INSTRUCTIONS FOR OPERATOR

1. When trailer is ready for use don't stand between trailer & the tractor.
2. Properly fit the drawbar & lock with lynch pin.
3. Never turn the tractor to the right or left when the trailer is raised.
4. Before you start working, please check all nuts & bolts of the trailer.
5. Be vigilant about the trees, poles and cables.

FIELDKING – THREE WAY TIPPING TRAILER

5. General

5.1 INTRODUCTION

The 3 side tipper mechanism does a great job by unloading the goods in three directions as now a days trailer unloads only in one direction which requires more space, time and fuel, so to overcome these problems we have three way tipper mechanism which is economical and efficient.

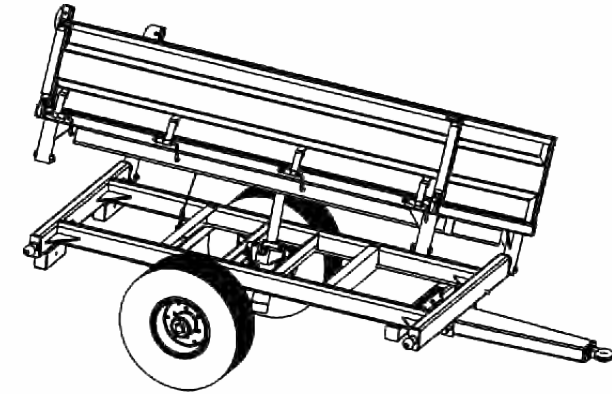

It is possible to tip in rear as well as sideways. The FIELDKING 3 WAY TIPPING TRAILER is therefore provided with hinges at every corner point. Locking pins have been provided for these hinges. Decide the location of the pins according to the side on which tipping will take place. There are three possibilities:

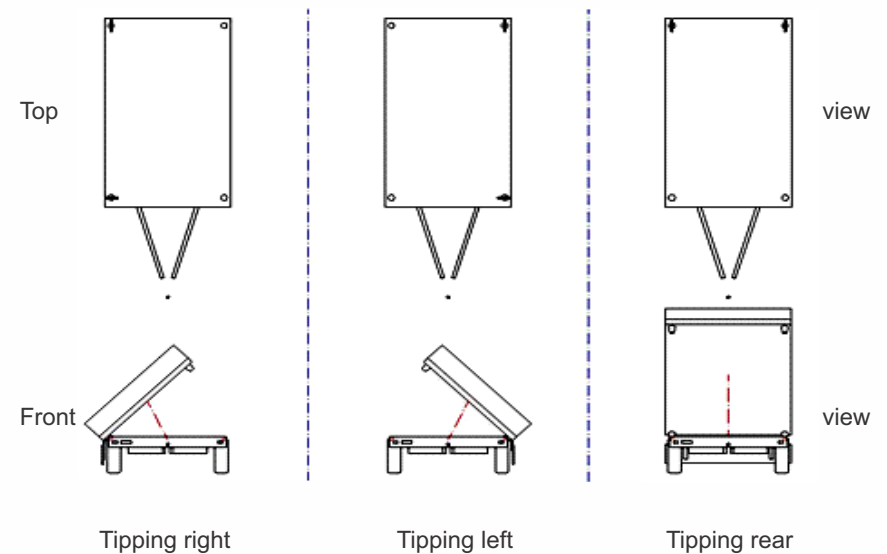

ATTENTION: Placing the pins "diagonally" (for example, left-front and right-rear), tipping over a single pin will cause damage.

The pin must be placed in the hole of the recess (part of the hinge on the lifting platform) and under the ball (part of the hinge on the bottom frame). To insert it fully, turn it a quarter turn.

If tipping function is used, the following general aspects should be checked before tipping (specific actions for the tipper for each version have been given below):

- The trailer should be correctly coupled to the towing vehicle (which is on hand brake or in gear)
- The wheels of the trailer are placed on a stable base surface,
- The locking pins are correctly placed in the hinges
- No persons should be present near the vehicle,
- When you are on the open road: **ATTENTION:** Ensure that you are visible during the tipping operation on public roads. This is for your safety and that of other road users. During rear tipping, for example, the oncoming traffic from the rear cannot see the lighting and the reflectors during the unloading.

5.2 Maintenance

- Weekly inspection:
- Check the hinges (ball and recess) for dirt and clean the same if necessary.
- The hinge should be sufficiently greased. If necessary, apply grease.
- Check that the hydraulic hose is undamaged. It should be totally intact.

Attention:

If maintenance has to be done with the tipping platform in the raised condition, use the existing support. This may be placed after fully pumping out the cylinder. Thereafter, place the support under the tray and ventilate the cylinder. It should then first be checked whether the hook on the top frame is correctly placed in the recess of the support.

5.3 Annual inspection:

- The tipper should be inspected at least once a year by duly trained personnel in authorised workshops or service centres.

ATTENTION:

During sideways tipping, the top frame should not be tilted more than 45° sideways. There is danger of damage if you raise it beyond this position!

6. TROUBLE -SHOOTING CHART

FAULT	CAUSE	ACTION	NOTE
The hydraulic hoses do not come loose from the connectors	Hydraulic system pressure	Remove the pressure from the system	First close the possible ball faucets
Hub heats up	Bearing damaged, little grease in the hub, the hub is too loose/tight	Change the bearing when necessary. Lubricate the hub Adjust the tightness of hub the hub	See hub adjusting instructions
The platform lowers with jerks	Air in the tipping cylinders	No actions needed	Air is removed with use over time from the hydraulic system
The tipper does not rise	The quick coupling of the tipper hose is not compatible with the tractor connector	Change the quick coupling to a suitable one	Standard quick couplings are not necessarily compatible with each other, even though the couplings would attach to each other
The tipper rises a little or badly	There is little hydraulic oil leaks in the system	Check that there are no leaks in the hydraulics	
The platform will not lower	Hose breakdown valve is working Quick coupling is damaged	Check the condition of the hoses. Change the quick coupling	Platform lowers at too great-Speed. Choke the oil return flow

The normal wearing of the tipper trailer takes place safely and does not cause dangerous situations.

You must take into consideration that if the machine is used against traffic rules and safety instructions, or if the machine is overloaded and not serviced, there is always a danger of unusual wear or breakdown that may harm both people and the environment.



TECHNICAL DATA AND SPECIFICATION

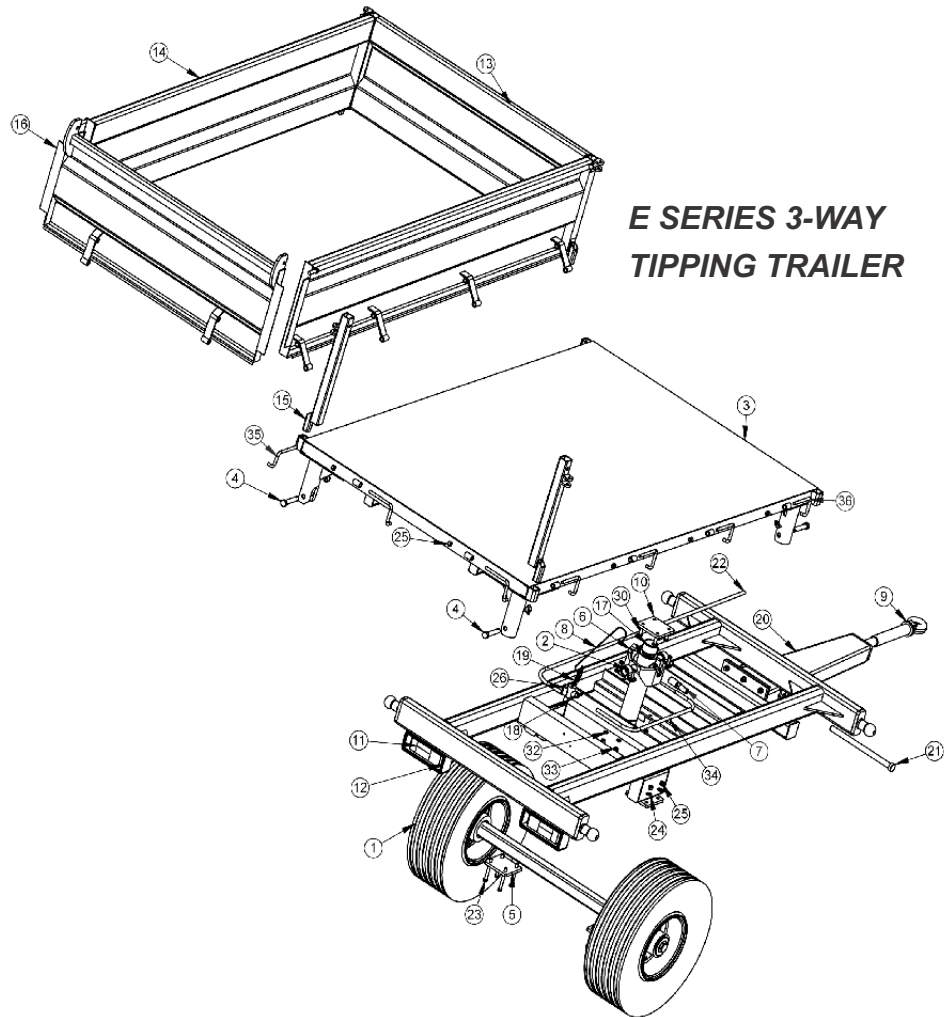

SrNo.	DESCRIPTION	TRAILER-5TON	TRAILER-9TON	TRAILER-5TON	TRAILER-9TON
		PartNo		Qty	
1	AXLE ASSEMBLY WITH TYRE	71430009	71430008		1
2	CYLINDER SUPPORT	10450021	10450026		2
3	UPPER CHASSI ASSEMBLY -3W	75240096	71470010		1
4	PIN 25X130MM	10020036			4
5	AXLE CLAMP 175X175X16MM(T)	72510003			2
6	CRADLE	10450020	10450025		1
7	NIPPLE	10450019			1
8	VALVE WIRE				1
9	RING HITCH (DAI 50X16INCH)	10430003	10430004		1
10	CYLINDER MOUNTING SMALL PLATE	72610005			1
11	TAIL LIGHT ASSEMBLY (WITH BULB)	11070001			2
12	LIGHT COVER	71350052			2
13	FRONT WINDOW ASSEMBLY(E SERIES)	71410013			1
14	SIDE WINDOW ASSEMBLY	72540011	72690004		2
15	REAR DOOR PILLAR ASSEMBLY (LEFT)	72610006			2
16	REAR DOOR ASSEMBLY(E SERIES)	72570003			1
17	3 WAY CYLINDER	10450018	10450024		1
18	VALVE	10450022			1
19	VALVE SPRING				1
20	DOWN CHASSI ASSEMBLY(3W)	71350036	71440009		1
21	LINK ROD-32X480	71350029			1
22	RUBBER PIPE	10200026	10200053		1
23	HEX HEAD BOLT 16X140X2MM(8.8 GRADE)	10260388			8
24	SPRING WASHER 16MM	10270005			8
25	NYLOCK NUT M16X2MM	10280005			18
26	HEX HEAD BOLT M8X40X1.25MM(8.8GRADE)	10260373			2
27	NYLOCK NUT M8X1.25MM	10280027			2
28	SPRING WASHER 8MM	10270001			2
29	LINCH PIN 10MM	10020022			4
30	HEX HEAD BOLT 16X50X2MM (8.8 GRADE)	10260358			4
31	HEX HEAD BOLT M14X60X2MM (8.8 GRADE)	10260399			4
32	SPRING WASHER 14MM	10270004			4
33	NYLOCK NUT M14X2 (P)	10280090			4
34	RUBBER PIPE .5 METER	10200020			1
35	LEFT LEVER DIA16X50X190MM (T)	10300113			4
36	RIGHT LEVER 16X50X190MM (T)	10300111			6

DELIVERY CHECKLIST

Dealer Pre-Delivery (Please Tick)	Please Complete all Dealer information Below
<p>1. Dealer Pre-Delivery Checklist</p> <ol style="list-style-type: none"> 1. The customer or person responsible has been given the operator's manual. 2. The customer undertakes to read the complete operator's manual and understands all aspects of the manual before operation of the machine. 3. All safety, operational and maintenance information have been explained and demonstrated. 4. All greasing and oil points, stickers, guarding and ID plate have been identified and physically pointed out. 5. The customer agrees that it is his responsibility to read and carry out the safety, maintenance and operation as per this operator's manual. 	<p>Dealer Information</p> <p>Dealer's Name.....</p> <p>Address.....</p> <p>State..... Postcode.....</p> <p>Phone..... Fax.....</p> <p>Email.....</p> <p>Service Person.....</p> <p>I confirm that the pre-delivery service was performed on this machine.</p> <p>Signature.....</p> <p>Date.....</p> <p>Comments.....</p>
Customer Delivery (Please Tick)	Please Complete all Customer Information Below
<p>2. Customer Delivery Checklist</p> <ol style="list-style-type: none"> 1. The customer or person responsible has been given the operator's manual. 2. The customer undertakes to read the complete operator's manual and understands all aspects of the manual before operation of the machine. 3. All safety, operational and maintenance information have been explained and demonstrated. 4. All greasing and oil points, stickers, guarding and ID plate have been identified and physically pointed out. 5. The customer agrees that it is his responsibility to read and carry out the safety, maintenance and operation as per this operator's manual. 	<p>Customer Information</p> <p>Customer's Name.....</p> <p>Address.....</p> <p>State..... Postcode.....</p> <p>Phone..... Fax.....</p> <p>Email.....</p> <p>Delivery Person.....</p> <p>I confirm that all of the delivery checks were explained and performed.</p> <p>Signature.....</p> <p>Delivery Date.....</p> <p>Comments.....</p>

FIELDKING

WARRANTY CARD Customer Copy

CUSTOMER NAME Mr./ Mrs. :

ADDRESS :

MOBILE NO. :

Email :

NAME OF IMPLEMENT :

MODEL NO. :

YEAR OF Mfg. :

SERIAL NO. :

REGISTRATION NO. :

DATE OF PURCHASING :

NAME OF DEALER :

Customer's Signature

Dealer's Signature



Beri Udyog Pvt. Ltd.

Corporate Office : Plot No. 235-236 & 238-240, Sec-3, HSIIDC,
 Karnal- 132001 (Haryana), India ☎ +91-184-2221571/ 72/ 73
 ✉ marketing@fieldking.com, exports@fieldking.com, 🌐 www.fieldking.com

FIELDKING

WARRANTY CARD Company Copy

CUSTOMER NAME Mr./ Mrs :

ADDRESS :

MOBILE NO. :

Email :

NAME OF IMPLEMENT :

MODEL NO. :

YEAR OF Mfg. :

SERIAL NO. :

REGISTRATION NO. :

DATE OF PURCHASING :

NAME OF DEALER :

Customer`s Signature

Dealer`s Signature



Beri Udyog Pvt. Ltd.

Corporate Office : Plot No. 235-236 & 238-240, Sec-3, HSIIDC,
Karnal- 132001 (Haryana), India

☎ +91-184-2221571/ 72/ 73
✉ marketing@fieldking.com, exports@fieldking.com, 🌐 www.fieldking.com

FIELDKING

WARRANTY CARD Dealer Copy

CUSTOMER NAME Mr./ Mrs :

ADDRESS :

MOBILE NO. :

Email :

NAME OF IMPLEMENT :

MODEL NO. :

YEAR OF Mfg. :

SERIAL NO. :

REGISTRATION NO. :

DATE OF PURCHASING :

NAME OF DEALER :

Customer's Signature

Dealer's Signature



Corporate Office : Plot No. 235-236 & 238-240, Sec-3, HSIIDC,
Karnal- 132001 (Haryana), India ☎ +91-184-2221571/ 72/ 73
✉ marketing@fieldking.com, exports@fieldking.com, 🌐 www.fieldking.com