

# FIELDKING

Disc Seed Drill



➤ [Operator Manual](#) ➤ [Service Manual](#) ➤ [Part Catalogue](#)

## CONGRATULATIONS!

You have invested in one of the best implements of its type in the market today.

The care you give your "FIELDKING" implement will greatly determine your satisfaction with its performance and its service life. A careful study of this manual will give you a thorough understanding of your new implement before operating.

If your manual is lost or destroyed, "FIELDKING" will be glad to provide you a new copy. Visit to nearest dealership & get a copy. Most of our manuals can also be downloaded from our website at [www.fieldking.com](http://www.fieldking.com).

As an authorized "FIELDKING" dealer, we stock genuine "FIELDKING" parts which are manufactured with the same precision and skill as our original equipment. Our trained service persons are well informed on methods required to service "FIELDKING" equipments and are ready to help you.

Should you require additional information or assistance, please contact us.

YOUR AUTHORIZED

FIELDKING DEALER

BECAUSE "FIELDKING" MAINTAINS AN ONGOING PROGRAMME OF PRODUCT IMPROVEMENT, WE RESERVE THE RIGHT TO MAKE IMPROVEMENTS IN DESIGN OR CHANGE IN SPECIFICATION WITHOUT INCURRING ANY OBLIGATION TO INSTALL THEM ON UNITS PREVIOUSLY SOLD. BECAUSE OF THE POSSIBILITY THAT SOME PHOTOGRAPHS IN THIS MANUAL WERE TAKEN OF PROTOTYPE MODELS, PRODUCTION MODELS MAY VARY IN SOME DETAIL. IN ADDITION, SOME PHOTOGRAPHS MAY SHOW SHIELDS REMOVED FOR THE PURPOSE OF CLARITY. NEVER OPERATE THIS IMPLEMENT WITHOUT ALL SHIELDS IN PLACE.

## TO THE PURCHASER

This manual contains valuable information about your new "FIELDKING" Disc Seed Drill . It has been carefully prepared to give you helpful suggestions for operating, adjusting, servicing and ordering spare parts.

Keep this manual in a convenient place for quick and easy reference. Study it carefully. You have purchased a dependable and sturdy Disc Seed Drill but only by proper care and operation you can expect to receive the service and long life designed and built into it.

Sometime in the future your Disc Seed Drill may need new parts to replace which are worn out or broken. If so, go to your dealer and provide him equipment's detail like model and part number.

## CUSTOMER INFORMATION

Name \_\_\_\_\_

Purchased From \_\_\_\_\_

Date of Purchase \_\_\_\_\_

Model No. \_\_\_\_\_

Serial No. \_\_\_\_\_

## PURCHASER / OPERATOR'S RESPONSIBILITY

1. Read and understand the information contained in this manual.
2. Operate, lubricate, assemble and maintain the equipment in accordance with all instructions and safety procedures in this manual.
3. Inspect the equipment and replace or repair any parts that are damaged or worn out which under continued operation would cause damage, wear to other parts, or cause a safety hazard.
4. Return the equipment or parts to the authorized "FIELDKING" dealer, from where it was purchased, for service or replacement of defective parts that are covered by warranty. (The "FIELDKING" Factory may inspect equipment or parts before warranty claims are honored.)
5. All costs incurred by the dealer for traveling to or transporting the equipment for warranty inspection and claims will be borne by the customer.

## INDEX

### 1. TECHNICAL DATA

- 1.1. Introduction
- 1.2. Warranty
- 1.3. When the warranty becomes void
- 1.4. Usage Instruction
- 1.5. Maintenance
- 1.6. Re-assembly parts

### 2. Major Components and their Description

- 2.1. Frame
- 2.2. Disc Openers
- 2.3. Seed and Fertilizer Boxes
- 2.4. Seed Metering Device
- 2.5. Fertilizer Metering Device
- 2.6. Power Transmission Unit
- 2.7. Depth-control Side Wheels
- 2.8. Hitch Points
- 2.9. Safety & equipment safety guideline

### 3. TIPS FOR OPERATION, MAINTENANCE AND

- 3.1. REPAIR
- 3.2. Planting Operations
- 3.3. Maintenance and Repair

## 1. TECHNICAL DATA

### 1.1 INTRODUCTION

#### DISC SEED DRILL

This handbook contains the use and maintenance instructions with a list of spare parts of Disc Seed Drill Machine.

Fieldking Disc Seed Drill Machine is high performance drill designed to sow seed of wide variety and size. Due to its precise metering system this is achieved accurately and economically.

Regular and satisfactory operations together with economic and long lasting use of the implement depends upon the compliance with instructions given in this book.

Compliance with instructions given in this handbook is also important since manufacturer declines all and every responsibility for damage to persons or property cause by negligence and failure to comply with these instructions.

### 1.2 WARRANTY

When the implement is delivered, check that it has not been subjected to damage during transport and that the accessories are in a perfect condition and complete.

Any claims following the receipt of damaged goods shall be presented in writing within 8 days from the receipt of the goods.

The purchaser may only make the claims under warranty. When he has complied with the warranty conditions in the supply contract.

### 1.3 WHEN THE WARRANTY BECOMES VOID

Besides the cases specified in the supply agreement, the warrantee shall in any case become void:

1. When the implement has been used beyond the specified power limit like (Tractor Horse Power)
2. When repairs made by the customer without authorization from the manufacturer or owing to installation of spurious spare parts, the machine is subjected to variations and the damage can be ascribed to these variations.
3. When the user has failed to comply with the instructions in this handbook.
4. No warranty will be given if the service and greasing is not done on time.

### 1.4. USAGE AND INSTRUCTIONS :

1. Check seed and fertilizer boxes, there should not be any metal piece or any hard material capable of damaging metering system.

2. Place the drill on leveled surface to adjust the depth of sowing as desired. By adjusting the height of side balancing wheel, and we can get the desired depth of sowing. For the vertical moment of balancing side wheels a special long bolt & nut arrangement is provided. By loosening and tightening the nut we can adjust the height of side balancing wheels. As we lower the wheels depth decreases and as we lift the wheel the sowing depth increases.



Fig.-1

3. Before sowing the front and rear disc should be in same horizontal plane, this leveling of disc can be adjusting the Top Link of tractor.
4. **Seed Metering Method** : For desired quantity that is to be sown can be adjusted with the help of grain index plate that is fixed on the seed box. On the grain index plate there is equal distance holes. There is lever that is move on the above said holes of index plate. A we step one hole to right side 10Kg- Acre can be decreased as we move lever to the left side. As we move 1 to 2 No. Seed quantity can be increased by 10Kg. The above said quantity is for wheat, corn and fertilizer (Fig-2).

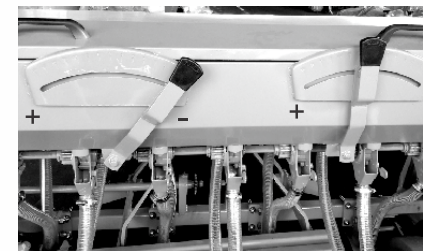

Fig-2 (Seed Meter & Fertilizer Meter)

5. **Fertilizer Metering** : There is also an index plate for fertilizer metering method which is provide on fertilizer box. Here the index plate is not holed type : it is graduated with the pre-caliberated scale. There is needle, which is moved on this plate, which indicates the quantity of fertilizers. The separate long fertilizer log lever is provided in front of the drill which is meant for the movement of needle (I.e to increase and decrease the quantity of fertilizer). With every increment (like 1 to2) 20 kg/Acre of fertilizer can increased or decreased. Don't touch or move the needle forcibly to increase or decrease the quantity of fertilizer, instead move the fertilizer lever. After adjusting the quantity of fertilizer lock the chuck nut, which is provided on the left side of the drill. Once after locking the chuck nut, when we again open the supply of fertilizer after closing the supply, the quantity will remain same, as we have adjusted before. (Be sure not to unlock the chuck nut) (Fig-2).

6. For keeping tension in the chain a special spring loaded idler is provided (Fig-3).
7. For observing the sowing operation a metallic platform is provided at the for sitting & standing helper (Fig-4).

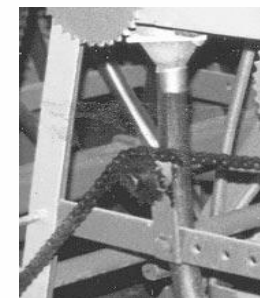

Fig-3

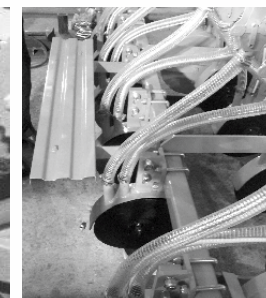

Fig.-4

### 1.5. MAINTENANCE

Although Seed Cum Fertilizer Disc Drill is relatively simple machine. The proper lubrication of the machine wherever is needed is highly important if satisfactory performance and long life are to be ensured



1. Oil and grease the all lubricating parts daily before sowing (All wheels, shaft and grease cup etc.)
2. There is a reel on the seed shaft that is beneath the seed box, grease this reel also, which is very important for the smooth working of seeding mechanism.
3. After sowing but before storing the seed take it to any service station so that the drill can be cleaned / washed through with the high pressure water spray. But remember after the Spray of water, apply diesel on both boxes with the help of brush or peace of cloth to prevent the box from rusting. It is important that the drill should be parked in covered area and away from sunlight.

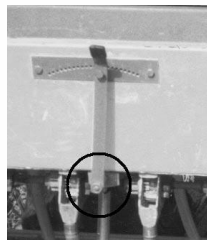

Fig-5

4. After regular intervals clean and paint both boxes.
5. To adjust row to row distance of tyne loosen the two "U" clamps of the tyne and set the distance as desired and than tighten the clamps fully (Fig-6).

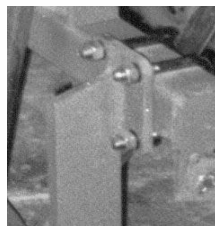

Fig.-6

6. Before re-using machine in next sowing season, all moving & rotating parts should work freely/properly.
7. To ensure the proper working oil all the moving/rotating parts like seed shaft, fertilizer shaft, front & side wheels and then rotate the front wheel with hand. Check that whether the parts are working properly or not. In case the parts are not working properly oil the moving parts especially in the router's hole in the fluted rollers (seed shaft). And after some time rotates the front wheel with hand again to check that is it moving/rotating freely (Fig-7).



Fig.-7

- 1.6 Re-Assembling of different parts of machine to right position for its proper working :

1. **CENTRAL WHEEL :** Central wheel is fixed inside the frame : take it out by loosing the bolt. It should be fixed in the center of machine at front. Fix it as shown in pictures.



Fig -8 (a)



Fig -8 (b)



Fig -8 (c)



Fig -8 (d)

After fixing the wheel, put tension spring in ring which is provided on wheel (see figures).

2. **FERTILIZER HANDLE :** The fertilizer handle is bolted under hopper. Loose the bolt and take the handle out. Now as shown in figures fix the handle in shown position. Bolt the handle in same hole but in right position. Do not forget to check nut it (Use double nut it).



Fig -9 (a)



Fig -9 (b)



Fig -9 (c)

3. **REAR PLATEFORM :** Fit the plate-form in vertical position as shown in figures and bolt it with frame.



Fig -10 (a)

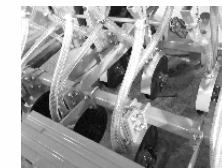

Fig -10 (b)

## 2. Major Components and their Description

- 2.1 **FRAME:-** 60×60mm sq.) welded together to provide the desired strength and rigidity. This is true in a drill of 9 discs but in 11-discs drill, the length of frame is about 176 cm.

### 2.2 **DISC OPENERS:-**

The Disc Seed Drill has 9-13 inverted disc's openers depending on the model or brand. These can be spaced as needed in different crops. These disc's openers when attached to a disc open a narrow slit 3-5 cm wide. In the disc's openers provided in Disc Seed Drill are spaced 17.5 cm apart. The cutting portion of the disc's openers is made by using 8 mm thick high carbon bit welded to a mild steel plate. The working front edge of the disc's openers has a piece of carbon steel (hardness 65 RHN) welded all round the nose, tip and sides to reduce wear and tear. In some drills, manufacturers have provided chisel type slit/furrow openers. The rake angle is generally kept at around 20 degrees in order to make a narrow slit with minimum of soil disturbance. The relief/clearance angle of the slit/furrow openers is normally kept at 5 degrees. The relief angle can be further adjusted with the help of the top link to vary seeding depth. A 4 cm wide, 5 cm thick and 6 cm long stiffener plate is provided at back bottom of the disc's opener (1.4 x 21.6 cm) which is attached to the frame with nuts and bolts or directly with clamps. The disc's opener is welded to the mild flat steel shank (straight leg standard mounted with disc's slit openers). The discs can be of "welded on" or "bolted on" or even "knock down" type. The disadvantage of "welded on" disc is that they require machine shop for replacement, whereas, a farmers himself can replace the other two types of disc. The quality of material used to make the disc's openers will ultimately decide the operational quality and durability of the Disc Seed Drill. Disc Seed Drill is provided behind each disc's opener to receive a tube (steel ribbon or polyethylene tube with a minimum diameter of 25 mm) each from seed and fertilizer metering devices. The disc's openers are adjusted to make 3-5 cm wide and deep slits. The depth of seeding can be adjusted by raising or lowering the depth-control side wheels. However, depth of seeding can also be adjusted (independent of the depth-control side wheels) by raising or lowering the shanks of the disc openers.

The depth control can also be effected with three point hitch hydraulics, in addition to the depth-control wheels. The top link is used to level the seeder. The UN-leveled machine may otherwise lead to variable seeding depth in different rows. The machine can be properly leveled by a three-point linkage. Since the side link hydraulics often get damaged or become non-functional in most tractors with the farmers, it is advisable to use the depth-control wheels or the top link.

### 2.3. SEED AND FERTILIZER BOXES

Seed and fertilizer boxes, made of mild steel sheet (2 mm thick), are mounted side by side on the frame, fertilizer box in front and seed box in the rear. Box dimensions can vary but these generally depend upon the effective width of the machine and will increase with the increase in the number of the disc's openers. For example in case of 11-disc, the length of seed and fertilizer boxes will be around 178 cm. Inner view of (a) Seed, and (b) Fertilizer boxes.

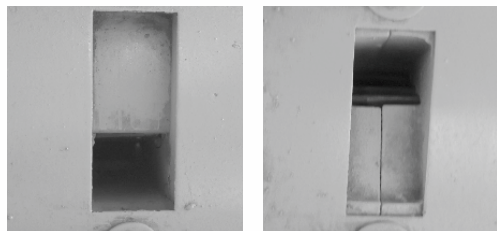

Fig-11(a) Seed Hole Fig-11 (b) Fertilizer Hole

### 2.4. SEED METERING DEVICE

Seed metering device has the following components

#### Calibration of seed-drill (in Laboratory)

3. Measure the diameter (D) of the drive wheel and calculate its circumference i.e.  $D$  in meters.
4. Measure the effective width of coverage in meters of the drilling machine by multiplying number of furrows with spacing.
5. Then distance/length (L) to cover one hectare is calculated by dividing 10000 m<sup>2</sup> (area of one hectare) by effective coverage
  - iv. The distance (l) i.e.  $l/100$ th of a hectare will be equal to  $L/100$  in meters.
  - v. To cover distance  $l$ , the drive wheel has to take 'n' turns i.e.  $= l/D$
  - vi. Allowing 10% slippage, the distance can be covered in 'N' turns i.e.  $= (n-0.1 n)$
  - vii. Raise the seed drill so that drive wheel becomes free to be turned. Put a chalk mark on the rim of the wheel. Fill the seed box, set the seed rate adjusting lever and rotate the wheel for 'N' turns.
  - viii. Weigh the quantity of seed dropped from each opener and record on the data sheet to know the variation in different rows, if any.

#### Example, say

- \* Circumference of the drive wheel = 0.4 m
- \* Width of machine = 2490 mm

- \* As we know area of one hectare = 10,000 m<sup>2</sup>
- \* Then distance/length (L) to cover one hectare will be  $= (10,000/2490) = 4016.06$  m
- \* The distance (l) i.e.  $1/100$  of hectare will be = 40.06 m
- \* To cover distance (l), the drive wheel has to take turns (n) =  $40.06/0.4 = 100.15$
- \* Allowing 10% slippage, the distance (l) can be covered in 'N' turns  $(n-0.1n) = 90.135$  (approx.).

Put seed and fertilizer in the boxes. Set the rate control adjustment lever as prescribed by the manufacturer.

#### Calibration of seed-drill

Select the recommended spacing (row to row spacing) and seed rate for the specific variety of crop to be sown.

Draw a line (dotted line as shown in Fig. 12) passing through the recommended spacing on line A, seed rate on line B and extend it further to join the line C of the monograph. This point of intersection on line C will give the desired seed quantity to be dropped per metre length per row.

#### Validation of the seed-drill calibration

Fill the seed box with seed and set the indicator at desired seed rate according to the chart given by the manufacturer. Mark a distance of 10 to 20 meters in the field. Run the seed drill and collect the seeds in each tube for 10 to 20 meter length run.

The amount of seed collected in each tube in 10 or 20 meter run is then expressed in g/ metre. This quantity should be equal to the calculated seed quantity obtained from the monograph in g/meter length/row. If the measured quantity is less or more, adjust the rate with the help of seed metering lever. Sliding the roller out will increase seed rate. Now, the seed drill is ready for planting the specific seed.

#### Example:

Supposition: Seed rate planned = 40 kg/acre Spacing row to row = 17.5 cm Plant to plant spacing = continuous

Draw a straight line (dotted line as shown in Fig) joining 17.5 cm on line A and 40 kg/ acre on line B and extend it further to intersect on line C at seed rate 1.8 g/meter length/row. So, the amount of seed for 10 meter length run per row =  $1.8 \times 10 = 18.0$  g. Therefore, the farmer should collect 18.0 g seed in each tube for 10 meter run of the machine in the field. If the quantity of seed collected is low/high, then he should adjust it with the metering lever. If we know the seed test weight (weight/1000 seeds) we can calculate the number of seeds/ meter row length using the intersected value (e.g. 1.8 g, Fig. 12) as follows.

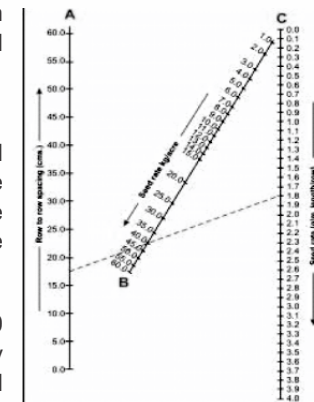

Fig. 12. Monograph for seed-drill calibration.

No. of seeds/meter row length (x) = 1000/seed test weight × 1.8 g.

Since the farmers do not have weighing machines, it is advisable to calibrate with seed number/m row length. For this it is better to calibrate number of seeds with the number of revolutions of the drive wheel. If the circumference of the drive wheel is one m, then the length covered in 1 turn is also one meter. and x number of seed will fall.

## 2.5. FERTILIZER METERING DEVICE

Metering device. In the bottom of the fertilizer box, diamond shape holes are made. The quantity of fertilizer is adjusted by adjusting the size of these holes. Star shaped agitators are provided to avoid the bridging of fertilizer and to feed fertilizer continuously through the holes. The fertilizer setting handle/lever with scale is provided to adjust the required quantity of fertilizer. The fertilizer passes through the hole, into a funnel, to deliver fertilizer into the slit/ furrow opener boots.

In other machines, fertilizer box delivers the material to a cup fitted with rotating cells (Fig. 12). The rotating cells pick up the fertilizer granules (small or large) and deliver them to the fertilizer tubes. This mechanism has the advantage of handling small or large sized fertilizer granules such as urea super granules (USG) and place them at desired soil depth. Deep placement of USG in rice culture is known to improve efficiency by 20%. Also there is no free flow of fertilizers on turnings of the tractor at field corners.

The rotating cell type fertilizer metering device has the following components (Fig. 13):

1. Fertilizer tank
2. Shaft
3. Fluted Rollers
4. Funnel
5. Leveling screw



Fig.-13 (a)

Fig.-13 (b)

### Fluted feed type

It is a seed metering devices with adjustable fluted rolled to collect and delivery the fertilizer into the fertilizer tube. Feed type Mechanism consists of a fluted feed wheel feed roller, feed cut-off and adjustable gate for different sizes of grains.

Fertilizer is simply metered by a series of cups on a roller. However, calibration of machine for setting required rate of fertilizer under laboratory situation can be accomplished with similar procedure mentioned earlier under the headings “Calibration of seed-drill (in laboratory)” and “Calibration of seed-drill.”

## 2.6. POWER TRANSMISSION UNIT

Power transmission unit (Fig.14) has the following main components:

1. Drive wheel
2. Shaft
3. Idler
4. Sprocket

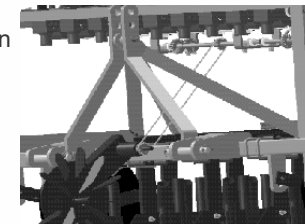

Fig. 14. Power transmission unit and its main components.

### Roller chain

The power required to operate the seed and fertilizer metering devices is provided by a floating type lugged drive wheel 40 cm in diameter and 10.5 cm in width through chain and sprockets. However, size of the drive wheel may vary in different models. Fourteen lugs each of 3 cm height at an angle of 90° are provided on the ground wheel to avoid slippage. Wheels are of iron closed type or with rubber on them for better traction. This ground wheel or drive wheel is attached to the frame in front. Traction can be adjusted through a groove and spring as desired. Attachment of drive wheel in the front side of the frame sometimes creates problem in the free movement of wheel due to soil or stubble blockage or due to its location being very near to the hook of the tractor. A motorcycle roller chain of 12.50 mm pitch with 14 and 37 number of teeth on the mild steel sprocket is provided for power transmission from the drive wheel to seed and fertilizer metering devices. Power from ground wheel is transmitted to a shaft (1:1) (Fig. 15) mounted on front frame. From this shaft power is transmitted to seed and fertilizer metering shafts (2.5:1) through the chain sprocket arrangement. However, size of roller chain and sprocket can vary in different models as per requirements. An idler has been provided to tighten or loosen the chain for its smooth running.



Fig-15 Drive Wheel attached on the Front Side

## 2.7. DEPTH-CONTROL SIDE WHEELS

Two wheels (one on either side of the drill), each of 40 cm diameter (Fig. 16a) made of mild steel sheet (closed type) or in some models made of rubber, are provided to set the required seeding depth. The size of these wheels may vary in different models. With the help of depth adjusting screws (Fig.16b), these wheels can be raised or lowered to increase or decrease the depth of seeding, respectively. The depth of seeding in case of wheat varies from 3–5 cm. However it can be adjusted as per requirement.



(Fig. 16a) Depth-control side wheel

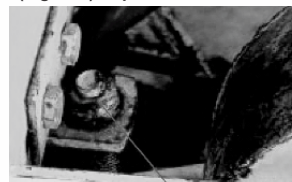

(Fig. 16b) Depth-adjusting screw

If there is a large amount of loose straw in the field, these depth wheels can get jammed with the straw. If this happens, the depth-control wheels can be removed and depth control maintained with the tractors' hydraulics, to reduce straw jamming.



## 2.8.HITCH POINTS

The drill has three standard hitch points; two lower and one upper (Fig. 17). The machine is attached to tractor through these three hitch points with the help of link pins. The top link hitch point also helps in leveling the machines

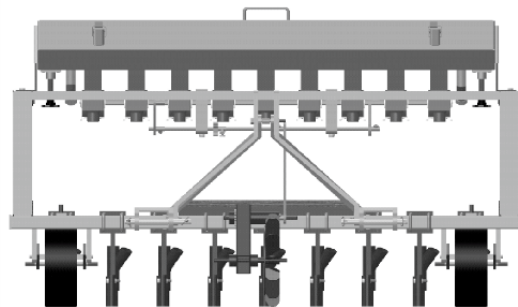

Fig. 17. Hitch points.

## PRECAUTIONS FOR USE

1. Sowing of wheat with seed-cum-fertilizer drill is best accomplished when soils have 3-4% more moisture than under conventional method. Germination of wheat and corn crops is adversely affected if the soil is too dry.
2. Conversely, Disc Seed Drill Machine does not work well in fields where moisture levels are too high (wheel slippage) and under such situations care must be taken to prevent blockage of seed and fertilizer tubes.
3. Heat stress at grain filling is less in late winter season when temperature begins to rise. The overall growth period of crop is more in early sowing.
4. Longer duration varieties such as PBW 343, HD 2687 having better vigor at early growth and profuse cultivating cover the soil surface and are more competitive with weeds.
5. The quantity of fertilizer or seeds are use in hopper by standard.
6. When weed pressure is not a factor, tilling of soil is not needed and reduced tillage (1-2 ploughings) and cross-sowing methods do not provide any additional advantage over seeding. Rather these methods may reduce germination and yield and induce germination of P. minor besides increasing the cost of cultivation.
7. It has been observed that farmer can skip the use of herbicides when zero tillage and alternate herbicides are carefully integrated for 3-4 years.
8. Irrigation immediately after sowing of wheat is not recommended. If needed, post-sowing.
9. Operator only sit on stand and not give the pressure of hands on machine.

## DISC SEED DRILL 9 , 11 & 13 TYNE (For Wheat Only)



Fig. 18

## DISC SEED DRILL 9 , 11 & 13 TYNE (For Multi Crop)

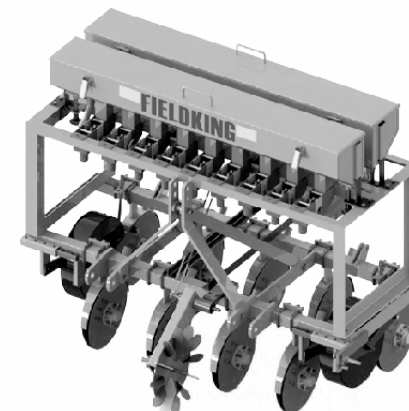

Fig. 19

## 3. TIPS FOR MANUFACTURERS, OPERATION, MAINTENANCE AND REPAIR

### 3.1 Repair

1. Machine should be of good quality and manufactured according to appropriate design specifications/drawing.
2. Frame shanks and disc's openers should be strong and made of proper material.
3. Provision should be made for replaceable parts on wear and tear.
4. There should be stress-free and proper alignment of components without any inbuilt stress assembly.
5. Testing before marketing should be ensured at manufacturer level.
6. Spare parts, critical components, nuts and bolts or clamps should be of high strength and standard quality.
7. Minimum tool kit should be provided.
8. Packing, handling and transportation should be proper.
9. Pooled service should be provided free of cost for replacement of parts or complete machine, if there is any defect or breakage during transportation.
10. Manufacturer should incorporate required modification based on feed back from time to time.

### 3.2 Planting Operations

Following points must be kept in mind before actual planting operation:

1. Seed should be of good quality and free from dirt and dust.



2. Fertilizer should not have clods. Clods should be properly broken to uniform size for free flow of fertilizer.
3. All the nuts and bolts, rollers and springs should be thoroughly checked, defective parts should be replaced and nuts/bolts properly tightened.
4. Seed and fertilizer boxes, fluted rollers, fertilizer metering shaft and controlling bottom plate (having triangular holes) should be thoroughly cleaned.
5. Fluted roller shaft should move freely, otherwise the rollers may be broken.
6. Feed cups should be thoroughly cleaned and obstruction if any, must be removed.
7. Ensure that plastic pipes do not have excessive bend. This will block the free flow of seed and fertilizer in tubes.

Chain sprocket of metering mechanism should be properly aligned. Appropriate tension in the chain may be kept for free movements of seed and fertilizer metering shafts. If there is any noise during operation, stop the machine and check it.

- \* Disc's openers should be fitted on the frame according to the requirement (row to row distance) of the crop. There should be no crossing or twisting of furrow openers.
- \* Fill the seed and fertilizer boxes and calibrates the machine. Ensure that seed drill is set at desired seed and fertilizer rates. This will ensure proper metering of seed and fertilizers and result in excellent germination, good crop stand and higher yield.

### 3.3 MAINTENANCE AND REPAIR

A well maintained and properly adjusted seeding machine gives trouble free service for a long time. It also helps in timely completion of operations. The following important points may be kept in mind for the maintenance and repair of various components of the seeding machines.

#### A. SEED AND FERTILIZER BOXES

The boxes should be thoroughly cleaned as these may rust very fast due to environmental moisture. This will damage the boxes and machine will not be useful for the next crop sowing season. The boxes must be cleaned as under:

1. Raise the machine above ground so that the drive wheels move freely
2. Remove seed and fertilizer from boxes.
3. Open the flow gates of seed and fertilizer cups.
4. Rotate the drive wheel till the seed and fertilizer from different seed and fertilizer cups are emptied. Clean the boxes and cups with the help of a cloth or brush.
5. Wash the machine rollers/seed/fertilizer boxes with diesel to avoid rusting.

6. Apply lubricating oil at appropriate places (bushes and sides of metering rollers).

#### B. DRIVE/POWER TRANSMISSION SYSTEM

For maintenance of drive system/power transmission system, keep following points in mind:-

1. Drive wheel should move freely. If it is jammed, then apply grease or put oil in its bushes. If axle of wheel is bent or worn out, replace it.
2. Drive wheel should be round, if it is bent then repair it.
3. Sprockets of drive wheel and feed shafts (seed and fertilizer boxes) should be properly aligned.
4. All sprockets should be properly tightened on their shafts so that these may not move freely on these shafts.
5. Feed shafts should move freely. If these are jammed due to rusting,, then clean and apply lubricating oil/grease in the bushes.
6. Bent drive shafts should be repaired or replaced.
7. Seed and fertilizer boxes should be thoroughly cleaned for free movement of feed shafts.
- 8.Chain and idler sprocket should be properly tightened so that proper chain tension is maintained and mechanism moves freely.

#### 9. Worn out parts, loose, broken and worn out bushes should be replaced.

#### C. SEED METERING MECHANISM

Usually fluted roller type seed metering mechanism is used in these seeding machine. It should be repaired and maintained as under.

1. Side plate of seed metering shaft sprocket should be removed by loosening nuts/ bolts.
2. Remove the nuts/bolts of all the seed cups.
3. Remove pins of all the fluted rollers.
4. Remove metering rollers from the seed cups and replace broken rollers and notched plates.
5. Take out the shaft on one side. All rollers will come out of seed cups.
6. During refitting of rollers, it must be ensured that all the rollers are at equal distance in the seed cups. If distance is different, then put washers to achieve equal distance.
7. Put the rollers on the shaft and put again on the seed box.

- Complete system should move freely and rotate the sprocket till appropriate seed rate is achieved from all the rollers.

#### D. FERTILIZER METERING MECHANISM

In fertilizer metering mechanism, fertilizer settles on its parts due to environmental moisture which may cause obstruction in free and uniform flow of fertilizer. Large particles also cause hindrance in the mechanism. In some of the seeding machines, adjustable triangular holes with agitator are provided for fertilizer metering. Therefore, this system requires special attention as follows:

- After seeding a crop, fertilizer should be removed from the box and whole system should be cleaned with the help of brush or cloth.
- If the system is jammed due to corrosion and rusting, the lower plate having triangular holes must be removed and cleaned with kerosene or diesel.
- All the holes in the box should be properly open.
- Agitators provided on the shaft should also be cleaned and the lubricating oil/grease may be applied in the bushes of the fertilizer metering shaft.
- Lever for adjustment of fertilizer rates should move freely.
- Tighten all nuts and bolts of the mechanism.

Likewise in other seeding machines which possess rotating cup type metering device should also be cleaned carefully. Each compartments, cup/cell and funnel should be free from jamming and the roller should move freely.

#### E. SEED AND FERTILIZER TUBES

These are mostly plastic tubes connected to seed/fertilizer cups and their lower ends are connected to seed boots.

- Tubes should be connected to seed/fertilizer cups with the help of clamps so that these may not come out during field operation.
- Tubes should be protected from bending and breakage.
- Old/bent tubes should be replaced.
- Excessive bend in the tubes should be avoided otherwise the bend will cause obstruction in free flow of seed/fertilizer and results in non-uniform application of fertilizer in the field.

#### F. GENERAL

- All the components of the machine should be painted

- Machine should be protected from rain, dirt and dust etc. during its storage.
- Moving parts should be greased/oiled at regular intervals so that the machine gives a trouble free service for a long time.
- Users training will lead to improvement in the performance of the machines.

#### 9.TROUBLESHOOTING

PROBLEM	CAUSE	REMEDY
Seed not placed at desired depth	Adjustment of depth control wheel In not proper	Properly adjust the depth of furrow openers with the help of depth control wheel
Seed/fertilizer is not dropping from disc's openers	1.The seed/fertilizer box is empty. 2.The disc's opener or seed delivery Tube is blocked by soil/mud or Fertilizer /seed delivery pipe bent 3.Seed/Fertilizer metering wheel gem 4.The drive wheel does not Touch the ground 5.Broken chain/sprocket	Refill the seed fertilizer box  Clean mud out of the opener and/or Delivery tubes  Clean the seed and fertilizer from orange box Lower down the hitch to get the drive wheel in contact with the land. Change the broken part Put the machine on a fairly level ground and then level all the furrow openers with the help of top link/right lower link of the tractor.
Unequal depth of Seeding among different rows/disc's openers	Improper three point linkage balancing	

## Other Information About Seed Gun Setting

### Seed Gun Settings

Each seed gun is equipped with a four-position gate. The highest handle position shown is for small seeds, the second and third positions are for larger seeds. The fourth position (Handle rotated fully down below the bottom tab) sets the wide open to allow complete clean-out of seed gun. Seed quantity is based on the handle being set in the highest position. Typically, most seeds will use the highest handle position. If using larger seed and it is not discharging properly, you can try using the other two handle positions.

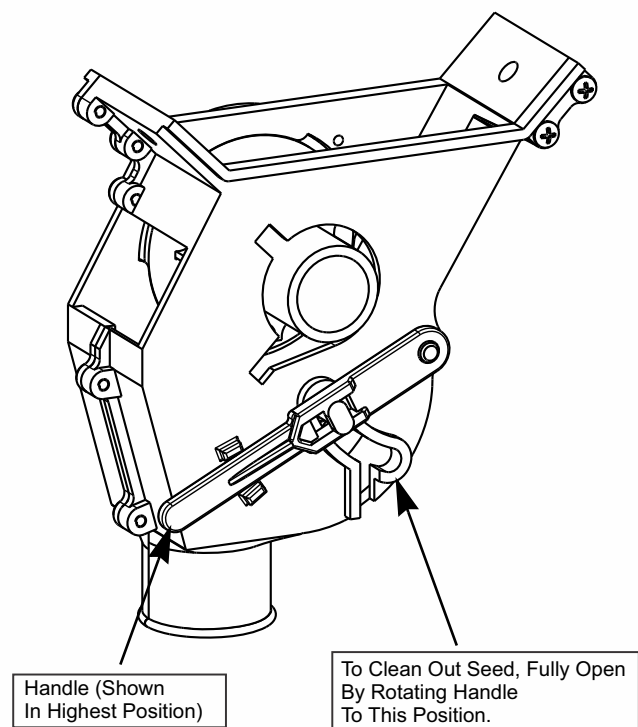

Fig-20

**IMPORTANT:** Most applications for this seeder require the handle be placed in the highest position.

**MAKE SURE** all handles are in the same position before seeding. Do Not set handles in the fourth position and seed quantity adjustment lever to the widest open position with seed in the box unless complete clean out is desired.

## FIELDKING DISC SEED DRILL (DISC ASSEMBLY)

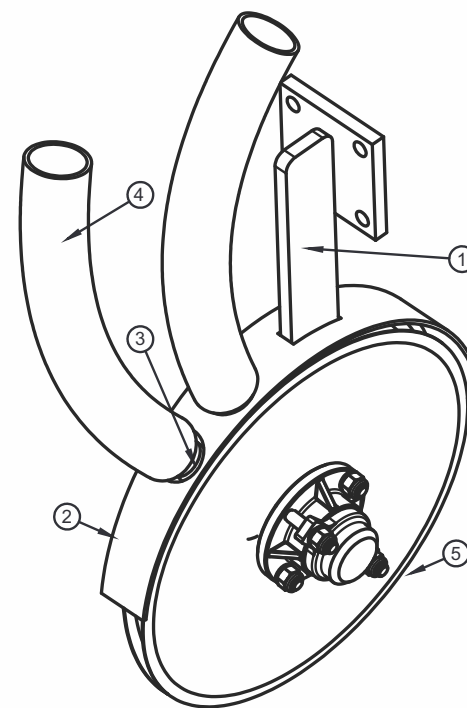

Fig-21

Sr. NO.	DESCRIPTION
1	FLAT
2	SEED PIPE HOLDING PLATE
3	SEED AND FERTILIZER PIPE
4	FLEXIBLE PVC PIPE
5	Disc

ROTOR No.	SEED DRILL / ZERO TILL ROTOR USE INSTRUCTIONS SHEET
	<b>INFORMATION FOR ROTOR NUMBER</b>
1	FOR GARLIC & FERTILIZER USE.
2	FOR BIG SIZE PEANUT (WITH WHEAT & FERTILIZER ) & FOR FERTILIZER USE.
3	SMALL SIZE PEANUT & BIG SIZE CORN , GRAM & FERTILIZER USE.
4	FOR SEASAME , MILLET , RAIDA , KIDNEY BEAN , TIDE & TUVAR.
	FOR SEASAME , MILLET , RAIDA 18 TEETH SPROCKET FRONT SIDE / 12 TEETH SPROCKET BACK FOR KIDNEY BEAN , TIDE & TUVAR 18 TETH SPROCKET BACK SIDE / 12 TEETH SPROCKET FRONT SIDE.
5	FOR SMALL CORN , GRAM ,SOYBEANS & WHEAT.
6	FOR SOWING CASTOR AT 30" DISTANCE WE USE 18 TEETH SPROCKET FRONT SIDE / 12 TEETH SPROCKET BACK SIDE.
	AT 15" DISTANCE WE USE 12 TEETH SPROCKET FRONT SIDE /18 TEETH SPROCKET FRONT SIDE.
7	FOR SOWING COTTON & TUVAR AT 15" DISTANCE 12 TEETH SPROCKET SHOULD BE FRONT SIDE /18 TEETH SPROCKET SHOULD BE BACK SIDE & FOR 30" DISTANCE 12 TEETH SPROCKET SHOULD BE BACK SIDE / 18 TEETH SPROCKET SHOULD BE FRONT SIDE.

## DELIVERY CHECKLIST

Dealer Pre-Delivery (Please Tick)	Please Complete all Dealer information Below
<p><b>1. Dealer Pre-Delivery Checklist</b></p> <ol style="list-style-type: none"> <li>The customer or person responsible has been given the operator's manual.</li> <li>The customer undertakes to read the complete operator's manual and understands all aspects of the manual before operation of the machine.</li> <li>All safety, operational and maintenance information have been explained and demonstrated.</li> <li>All greasing and oil points, stickers, guarding and ID plate have been identified and physically pointed out.</li> <li>The customer agrees that it is his responsibility to read and carry out the safety, maintenance and operation as per this operator's manual.</li> </ol>	<p><b>Dealer Information</b></p> <p>Dealer's Name.....</p> <p>Address.....</p> <p>State..... Postcode.....</p> <p>Phone..... Fax.....</p> <p>Email.....</p> <p>Service Person.....</p> <p>I confirm that the pre-delivery service was performed on this machine.</p> <p>Signature.....</p> <p>Date.....</p> <p>Comments.....</p>
Customer Delivery (Please Tick)	Please Complete all Customer Information Below
<p><b>2. Customer Delivery Checklist</b></p> <ol style="list-style-type: none"> <li>The customer or person responsible has been given the operator's manual.</li> <li>The customer undertakes to read the complete operator's manual and understands all aspects of the manual before operation of the machine.</li> <li>All safety, operational and maintenance information have been explained and demonstrated.</li> <li>All greasing and oil points, stickers, guarding and ID plate have been identified and physically pointed out.</li> <li>The customer agrees that it is his responsibility to read and carry out the safety, maintenance and operation as per this operator's manual.</li> </ol>	<p><b>Customer Information</b></p> <p>Customer's Name.....</p> <p>Address.....</p> <p>State..... Postcode.....</p> <p>Phone..... Fax.....</p> <p>Email.....</p> <p>Delivery Person.....</p> <p>I confirm that all of the delivery checks were explained and performed.</p> <p>Signature.....</p> <p>Delivery Date.....</p> <p>Comments.....</p>



# FIELDKING

## WARRANTY CARD Customer Copy

CUSTOMER NAME Mr./ Mrs :

ADDRESS :

MOBILE NO. :

Email :

NAME OF IMPLEMENT :

MODEL NO. :

YEAR OF Mfg. :

SERIAL NO. :

REGISTRATION NO. :

DATE OF PURCHASING :

NAME OF DEALER :

Customer's Signature

Dealer's Signature



**Beri Udyog Pvt. Ltd.**

**Corporate Office :** Plot No. 235-236 & 238-240, Sec-3, HSIIDC,  
Karnal- 132001 (Haryana), India ☎ +91-184-2221571/ 72/ 73

✉ marketing@fieldking.com, exports@fieldking.com, 🌐 www.fieldking.com

# FIELDKING

## WARRANTY CARD Company Copy

CUSTOMER NAME Mr./ Mrs :

ADDRESS :

MOBILE NO. :

Email :

NAME OF IMPLEMENT :

MODEL NO. :

YEAR OF Mfg. :

SERIAL NO. :

REGISTRATION NO. :

DATE OF PURCHASING :

NAME OF DEALER :

Customer's Signature

Dealer's Signature



**Beri Udyog Pvt. Ltd.**

**Corporate Office :** Plot No. 235-236 & 238-240, Sec-3, HSIIDC,  
Karnal- 132001 (Haryana), India

+91-184-2221571/ 72/ 73  
✉ marketing@fieldking.com, exports@fieldking.com, 🌐 www.fieldking.com

# FIELDKING

## WARRANTY CARD

Dealer Copy

CUSTOMER NAME Mr./ Mrs :

ADDRESS :

MOBILE NO. :

Email :

NAME OF IMPLEMENT :

MODEL NO. :

YEAR OF Mfg. :

SERIAL NO. :

REGISTRATION NO. :

DATE OF PURCHASING :

NAME OF DEALER :

Customer's Signature

Dealer's Signature



**Beri Udyog Pvt. Ltd.**

**Corporate Office :** Plot No. 235-236 & 238-240, Sec-3, HSIIDC,  
Karnal- 132001 (Haryana), India

+91-184-2221571/ 72/ 73  
✉ marketing@fieldking.com, exports@fieldking.com, 🌐 www.fieldking.com