

FIELDKING

High Speed Disc Harrow

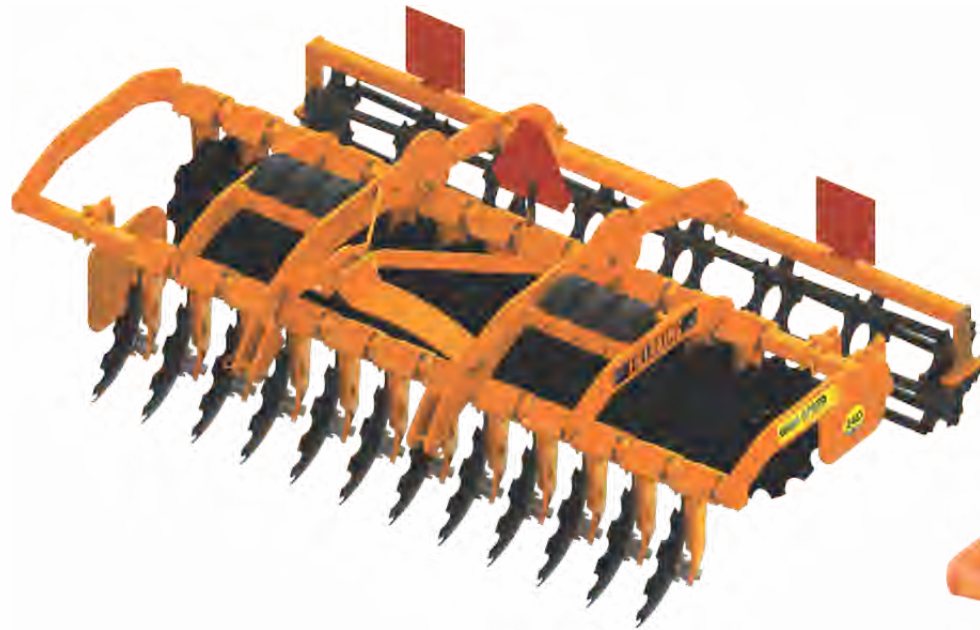

➤ [Operator Manual](#) ➤ [Service Manual](#) ➤ [Part Catalogue](#)

CONGRATULATIONS!

You have invested in one of the best implements of its type in the market today.

The care you give your "FIELDKING" implement will greatly determine your satisfaction with its performance and its service life. A careful study of this manual will give you a thorough understanding of your new implement before operating.

If your manual is lost or destroyed, "FIELDKING" will be glad to provide you a new copy. Visit to nearest dealership & get a copy. Most of our manuals can also be downloaded from our website at www.fieldking.com.

As an authorized "FIELDKING" dealer, we stock genuine "FIELDKING" parts which are manufactured with the same precision and skill as our original equipment. Our trained service persons are well informed on methods required to service "FIELDKING" equipments and are ready to help you.

Should you require additional information or assistance, please contact us.

YOUR AUTHORIZED
FIELDKING DEALER

BECAUSE "FIELDKING" MAINTAINS AN ONGOING PROGRAMME OF PRODUCT IMPROVEMENT, WE RESERVE THE RIGHT TO MAKE IMPROVEMENTS IN DESIGN OR CHANGE IN SPECIFICATION WITHOUT INCURRING ANY OBLIGATION TO INSTALL THEM ON UNITS PREVIOUSLY SOLD. BECAUSE OF THE POSSIBILITY THAT SOME PHOTOGRAPHS IN THIS MANUAL WERE TAKEN OF PROTOTYPE MODELS, PRODUCTION MODELS MAY VARY IN SOME DETAIL. IN ADDITION, SOME PHOTOGRAPHS MAY SHOW SHIELDS REMOVED FOR THE PURPOSE OF CLARITY. NEVER OPERATE THIS IMPLEMENT WITHOUT ALL SHIELDS IN PLACE.

TO THE PURCHASER

This manual contains valuable information about your new "FIELDKING" high speed disc harrow. It has been carefully prepared to give you helpful suggestions for operating, adjusting, servicing and ordering spare parts.

Keep this manual in a convenient place for quick and easy reference. Study it carefully. You have purchased a dependable and sturdy high speed disc harrow but only by proper care and operation you can expect to receive the service and long life designed and built into it.

Sometime in the future your high speed disc harrow may need new parts to replace which are worn out or broken. If so, go to your dealer and provide him equipment's detail like model and part number.

CUSTOMER INFORMATION

Name _____

Purchased From _____

Date of Purchase _____

Model No. _____

Serial No. _____

PURCHASER / OPERATOR'S RESPONSIBILITY

1. Read and understand the information contained in this manual.
2. Operate, lubricate, assemble and maintain the equipment in accordance with all instructions and safety procedures in this manual.
3. Inspect the equipment and replace or repair any parts that are damaged or worn out which under continued operation would cause damage, wear to other parts, or cause a safety hazard.
4. Return the equipment or parts to the authorized "FIELDKING" dealer, from where it was purchased, for service or replacement of defective parts that are covered by warranty. (The "FIELDKING" Factory may inspect equipment or parts before warranty claims are honored.)
5. All costs incurred by the dealer for traveling to or transporting the equipment for warranty inspection and claims will be borne by the customer.

INDEX

1. TECHNICAL DATA

- 1.1 Introduction
- 1.2 Warranty
- 1.3 When the warranty becomes void
- 1.4 Warning

2. USAGE INSTRUCTIONS

- 2.1 Before Use & Adjustments
- 2.2 High speed disc harrow part Assembly
- 2.3 Attaching Harrow to the tractor
- 2.4 Warning for driver
- 2.5 Safety
- 2.6 Safety Sticker

3. MAINTENANCE

- 3.1 Maintenance Instructions
- 3.2 Storage of machine after work
- 3.3 Lubrication
- 3.4 Instruction for driver

4. OPERATIONAL GUIDELINES FOR HARROW

1. TECHNICAL DATA

1.1 INTRODUCTION

This handbook contains the use and maintenance instructions with a list of the spare parts of the Disc Harrow.

This Disc harrow is equipped with heavy-duty box frame specially designed for harrowing / land preparation of rough soil (Secondary finer operation).

Regular and satisfactory operation together with economic and long lasting use of the implement depends on the compliance with instructions given in this handbook.

Compliance with the instructions in this handbook is also important since Manufacturer declines all and every responsibility for damage to persons or property caused by negligence and failure to comply with these instructions. It is designed to work in extreme condition for speed up to 20 Km/h. Both side notched discs are used for intense mixing. Anti vibration shock absorber rubber are used to mount leg assembly with main frame heavy duty square pipe.

1.2 WARRANTY

When the machine is delivered, check that it has not been subjected to damage during transport and that the accessories are in a perfect condition and complete. Any claims following the receipt of damaged goods shall be presented in writing within 8 days from the receipt of the goods. The purchaser may only make the claims under warranty when he has complied with the warranty conditions in the supply contract.

1.3 WHEN THE WARRANTY BECOMES VOID

Besides the cases specified in the supply agreement, the guarantee shall in any case become void:

When the implement has been used beyond the specified power limit like (Tractor Horse Power) When repairs made by the customer without authorization from the manufacturer or owing to installation of spurious spare parts, the machine is subjected to variations and the damage can be ascribed to these variations. When the user has failed to comply with the instructions in this handbook. If the implement is used in very hard/stony soil no warranty of discs will be given. No warranty will be given if the service and greasing is not done on time.

1.4 WARNING

Thoroughly read the instruction manual before proceeding with the various operations. Maintain the harrow as per the instructions of this handbook to be entitled for warranty.

2. USAGE INSTRUCTIONS

2.1 BEFORE USE & ADJUSTMENTS

1. Before mounting of disc harrow make sure that all nuts & bolts are properly secured.
2. Also determine soil and trash conditions of the field and make the preliminary adjustments. e.g.

a) **Disc harrow leveling:** - To eliminate uneven penetration and side draft, leveling is done by means of top link.

b) **Depth control:-** The depth at which the implement is required to work is controlled hydraulically by raising or lowering the control lever on the tractor.

c) **Disc harrow penetration :-** Factors affecting disc harrow penetration are:-

- Weight of the harrow
- Disc diameter
- Disc sharpness
(Blunt disc increases the draft considerably, check the disc sharpness)
- Angle of hitch

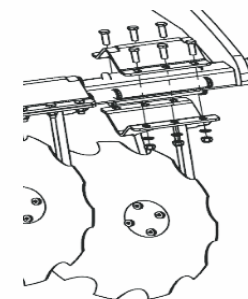

2.2 HIGH SPEED DISC HARROW PART ASSEMBLY

1. Firstly keep main frame on stand then mount individual leg assembly with rubber on main frame heavy duty square pipe with 85 Nm torque and other leg assembly at 250mm distance.

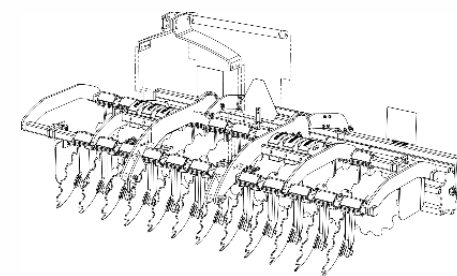

2. Mount three point linkage on main frame with help of high tensile bolt.

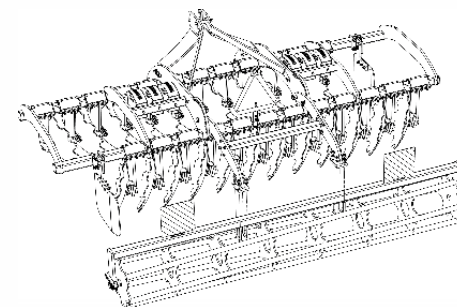

3. Mount complete crumbler assembly on high speed disc harrow crumbler mounting plate with help of U-Clamp and nut.

2.3 ATTACHING THE HARROW TO THE TRACTOR

1. Place the harrow duly leveled on the flat piece of land.
2. Reverse the tractor to the harrow (Do not drag the harrow up the tractor)
3. Attach the left arm of the tractor to the harrow first.
4. Attach the central arm to the harrow. To attach, turn the screws on both sides to an equal length. If the arm is too short or too long, turn the screw to adjust both at the same time until aligned with the hole on the central arm.
5. Attach the lower right arm, turn the screw until the mounting pin is at the same level as the hole on the tractor arm. If the gap between the hole and mounting pin is too close or too distant, turn the control arm in or pull it away to an appropriate distance. You may have to adjust both height and distance at the same time. When the hole at tractor arm and mounting pin are even, insert the pin in the hole and lock it with the lynch pin.
6. After attaching the harrow, lift it and adjust the control arm parallel to the ground. When you look from both rear or sideways, the discs should all be touching the ground uniformly.

2.4 WARNING FOR THE DRIVER

1. Before harrowing check all nuts & bolts of the disc harrow.
2. Be vigilant about the tree roots and stones. Don't harrow on stony soil.
3. Tractor should be in first high or fourth low gear.
4. Don't allow anyone to come across the harrow.
5. Lift the disc harrow on every turn.
6. Lift the harrow before approaching the road.

2.5 SAFETY

Understanding the Machine Safety Labels



Safety-Alert Symbol

The machine safety labels shown in this section are placed in important areas on your machine to draw attention to potential safety hazards

On your machine the words DANGER, WARNING, and CAUTION are used with this safety-alert symbol. DANGER identifies the most serious hazards.

The operator's manual also explains any potential safety hazards whenever necessary.

Before harrowing with disc harrow take care that nobody stands near it.



In order to protect yourself always wear adequate clothes and shoes during the operations.



Never use your hands to check hydraulic leaks. Escaping hydraulic oil under pressure may have sufficient force to penetrate the skin causing injury.



Never allow riders on the tractor or implement unless an additional seat is available.



Be careful when moving around steep gradient to avoid sharp turn.

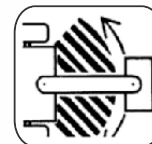

Never transport the implement on rough roads during the night. When operating, avoid sharp turns that may cause tractor colliding with the implement.

2.6 SAFETY STICKER

Take care that the bolts of the clamp plate are always tightened with the indicated torque. This offers the most effective working of the discs.

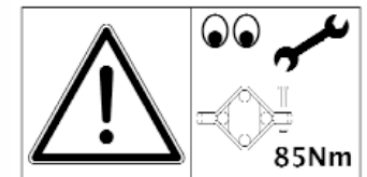

3. MAINTENANCE

3.1 MAINTENANCE INSTRUCTIONS

If you work the Disc harrow on stony land then maintenance also increases.

1. If the sand has entered the grease nipple, then change the nipple.
2. If disc harrow is new after initial working of first two hours, tighten all nuts & bolts.
3. After every fifty hours grease all greasing points with grease gun and tighten all nuts & bolts.
4. No Maintenance in Agri hub. Only one time use.

3.2 STORAGE OF MACHINE AFTER WORK

1. Wash the Disc harrow after work.
2. Replace the worn out nuts & bolts.
3. If disc harrow has to remain unused for long time then clean it & apply a layer of used oil for rust prevention.

These steps will enhance the life of your Disc harrow.

3.3 LUBRICATION

Please take care that high quality grease is used in bearing housing.

3.4 INSTRUCTIONS FOR DRIVER

1. When disc harrow is ready for use don't stand between disc harrow & the tractor.
2. Properly fit the three point linkage as mentioned above & lock with lynch pin.
3. In case of scrapper touching the discs, loosen the scrapper bolt and readjust the scrapper.
4. Never turn the tractor to the right or left when the harrow is engaged in the soil.
5. Never reverse the tractor when the harrow is engaged in the soil.
6. To get good results from the harrow, disc should be replaced when its diameter is reduced by 5" from its original size.

4. OPERATIONAL GUIDELINES FOR HARROW

1. Lift the harrow on turning for effective independent breaking of soil.
2. Adjust internal /external check chains to obtain implement swing range within 50 mm (2") when raised.
3. Always maintain the correct tyre pressure to avoid wheel slippage.
4. Adding of wheel weights/water ballasting or combination of both is recommended when excessive rear wheel slippage is experienced.
5. Always set hydraulic levers correctly for draft and position control operation.

Precautions during transportation:-

1. When transporting the harrow, shorten up top link to minimum length.
2. Set hydraulic levers in top raised position and lock levers.
3. Maintain the speed to avoid jumps.
4. Watch while overtaking on road.
5. Always use SMV (Slow Moving Vehicles) symbols.

PART LIST HIGH SPEED DISC HARROW

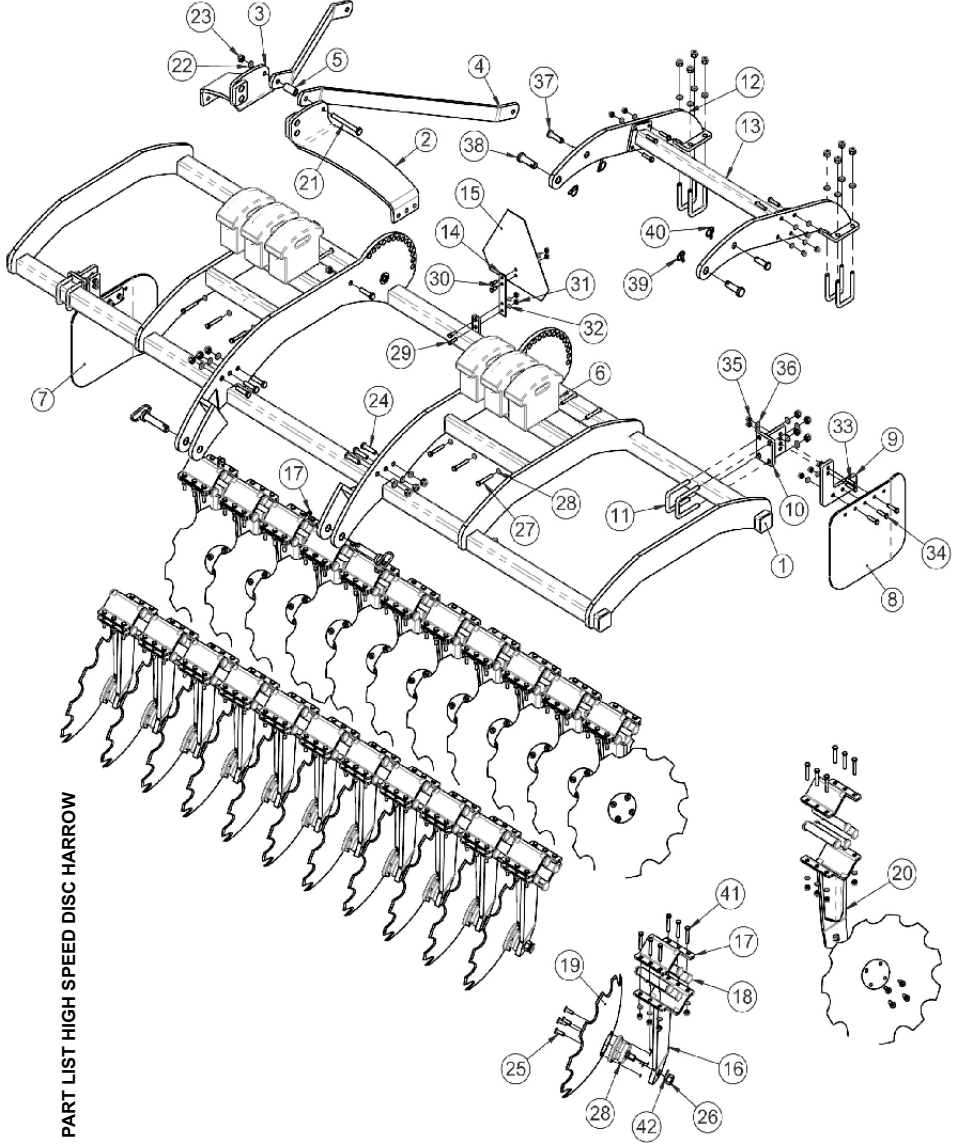

PART LIST HIGH SPEED DISC HARROW

SR. NO.	PART NAME	PART NO.						QTY							
		14x14	12x12	10x10	8x8	6x6	14x14	12x12	10x10	8x8	6x6				
1	MAIN FRAME ASSEMBLY	79010021	79010001	79910001	79910007	79010028						1			
2	FRONT LEVER RHS			79010006								1			
3	FRONT LEVER LHS			79010007								1			
4	REAR LEVER			79010009								2			
5	3-POINT LINKAGE BUSH			79010011								1			
6	HYDRAULIC HARROW WEIGHT (82 KG.)			01060022							14	6	6	6	6
7	FRONT SCRAPER			79030005								1			
8	REAR SCRAPER			79030004								1			
9	SCRAPER MOUNTING FLAT -I			79030002								2			
10	SCRAPER MOUNTING BRACKET			79030003								2			
11	U-CLAMP 16x90x130			10220026								8			
12	CRUMBLER MOUNTING PLATE ASSEMBLY			79070001								2			
13	CRUMBLER MOUNTING PLATE SUPPORT PIPE			79020005		790200032						1			
14	SMV TRIANGLE MOUNTING PLATE			79010018								1			
15	TRIANGLE REFLECTOR			20051185								1			
16	FRONT LEG ASSEMBLY			79040001							14	12	10	8	6
17	TOP CLAMP			79040004							28	24	20	16	12
18	RUBBER (EPDM) CUSHION			10300289							112	96	80	64	48
19	BORON STEEL NOTCHED DISC 22"x4.5T			10240088							28	24	20	16	12
20	BORON STEEL NOTCHED DISC 24"x4.5T			10240095							14	12	10	8	6
21	REAR LEG ASSEMBLY			79060001								1			
22	HEX HEAD BOLT M16x160Lx2.5P			10260044								25			
23	SPRING WASHER 16MM			10270005								25			
24	NYLOCK NUT M16x2P			10280005								8			
25	HEX HEAD BOLT M16x65Lx2P			10260017							112	96	80	64	48
26	HEX HEAD BOLT M12x1.25Px25L			10260479							28	24	20	16	12
27	HEX NUT M22x1.5 (P)			10280116								12			
28	HEX HEAD BOLT M12x90Lx1.75P			10260011							28	24	20	16	12
29	SKF AGRI HUB - 0183			10090049								2			
30	HEX HEAD BOLT M10x35Lx1.5P			10260353								2			
31	HEX HEAD BOLT M10x25Px1.5P			10260361								2			
32	NYLOCK NUT M10x1.5P			10280002								4			
33	SPRING WASHER 10MM			10270002								4			
34	HEX HEAD BOLT M12x45Lx1.75P			10260363								12			
35	HEX HEAD BOLT M12x45Lx1.75P			10260005								6			
36	NYLOCK NUT M12x1.75P			10280025							186	162	138	114	90
37	SPRING WASHER 12MM			10270003							198	174	150	126	102
38	PIN 19x70L			10020130								2			
39	PIN 25x60L			10020132								2			
40	LINCH PIN 10MM			10020022								2			
41	LINCH PIN 8MM			10020045								2			
42	HEX HEAD BOLT M12x70Lx1.75P			10260407							168	144	120	96	72
	SPRING WASHER 22MM			10270048							28	24	20	16	12

HIGH SPEED MULTI DISC HARROW 12X12 (DOUBLE COIL TYNE) 3MM

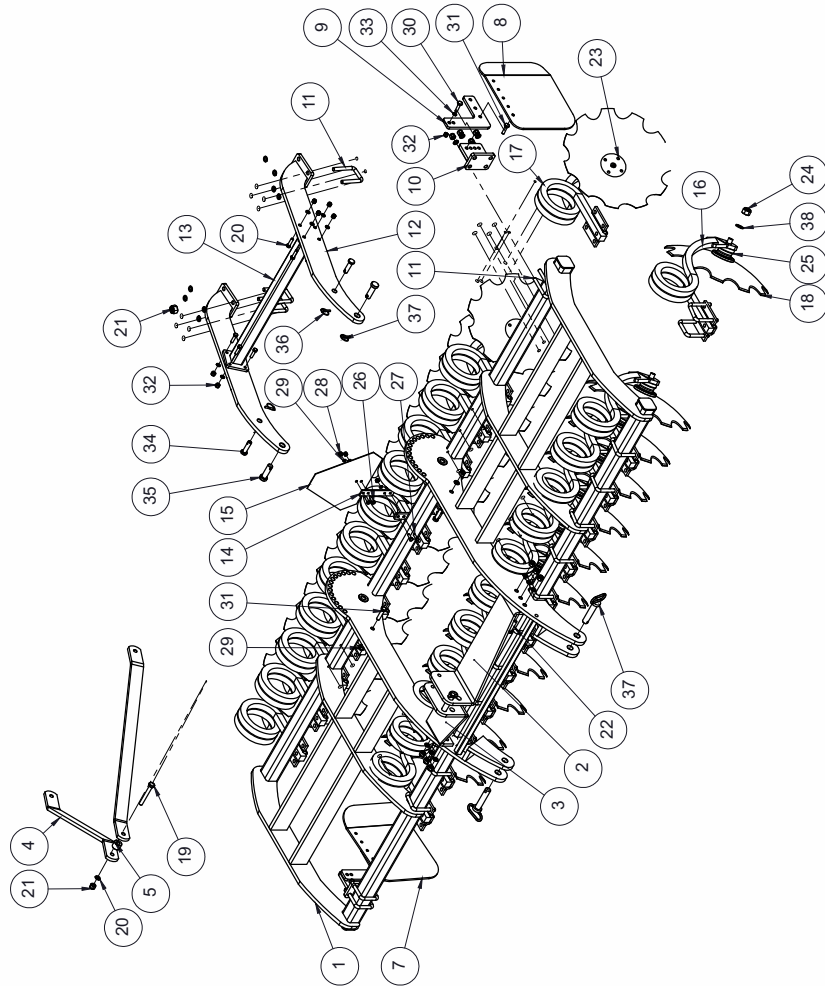

HIGH SPEED MULTI DISC HARROW 12X12 (DOUBLE COIL TYNE)

Sr. No.	PART NAME 12X12	PART NO. 12x12	QTY.
1	MAIN FRAME ASSEMBLY	79010042	1
2	FRONT LEVER RHS	79010006	1
3	FRONT LEVER LHS	79010007	1
4	REAR LEVER	79010009	2
5	3-POINT LINKAGE BUSH	79010011	1
7	FRONT SCARPER	79030004	1
8	REAR SCRAPER	79030005	1
9	SCRAPER MOUNTING FLAT-1	79030002	2
10	SCRAPER MOUNTING BRACKET	79030003	2
11	U-CLAMP	76630006	4
12	CRUMBLER MOUNTING PLATE ASSY.	79020033	2
13	CRUMBLER MOUNTING PLATE SUPPORT PIPE ASSY.	79020005	2
14	SMV TRIANGLE MOUNTING PLATE	79010018	1
15	TRIANGLE REFLECTOR	20051185	1
16	FRONT TYNE ASSY.	79040015	12
17	REAR LEG ASSEMBLY.	79040017	12
18	BORON STEEL NOTCHED DISC 22"x4.5T	10240088	24
19	HEX HEAD BOLT M16X160LX2.5P	10260044	1
20	SPRING WASHER 16MM	10270005	25
21	NYLOCK NUT M16X2P	10280005	25
22	HEX HEAD BOLT M16X65LX2P	10260017	8
23	HEX HEAD BOLT M12X25X1.25P	10260479	96
24	HEX NUT M22X1.5P	10280116	24
25	SKF AGRI HUB -0183	10090049	24
26	HEX HEAD BOLT M10X35LX1.5P	10260353	2
27	HEX HEAD BOLT M10X25LX1.5P	10260361	2
28	NYLOCK NUT M10x1.5P	10280002	4
29	SPRING WASHER 10MM	10270002	4
30	HEX HEAD BOLT M12x50x1.75P	10260363	12
31	HEX HEAD BOLT M12x45x1.75P	10260005	6
32	NYLOCK NUT M12x1.75P	10280025	18
33	SPRING WASHER 12MM	10270003	18
34	PINØ19x70L	10020130	2
35	PINØ25x80L	10020132	2
36	LINCH PIN 10MM	10020022	2
37	LINCH PIN 8MM	10020045	2
38	SPRING WASHER 22MM	10270048	24

MULTI DISC HARROW CRUMBLER WITH DOUBLE COIL TYNE (35MM)

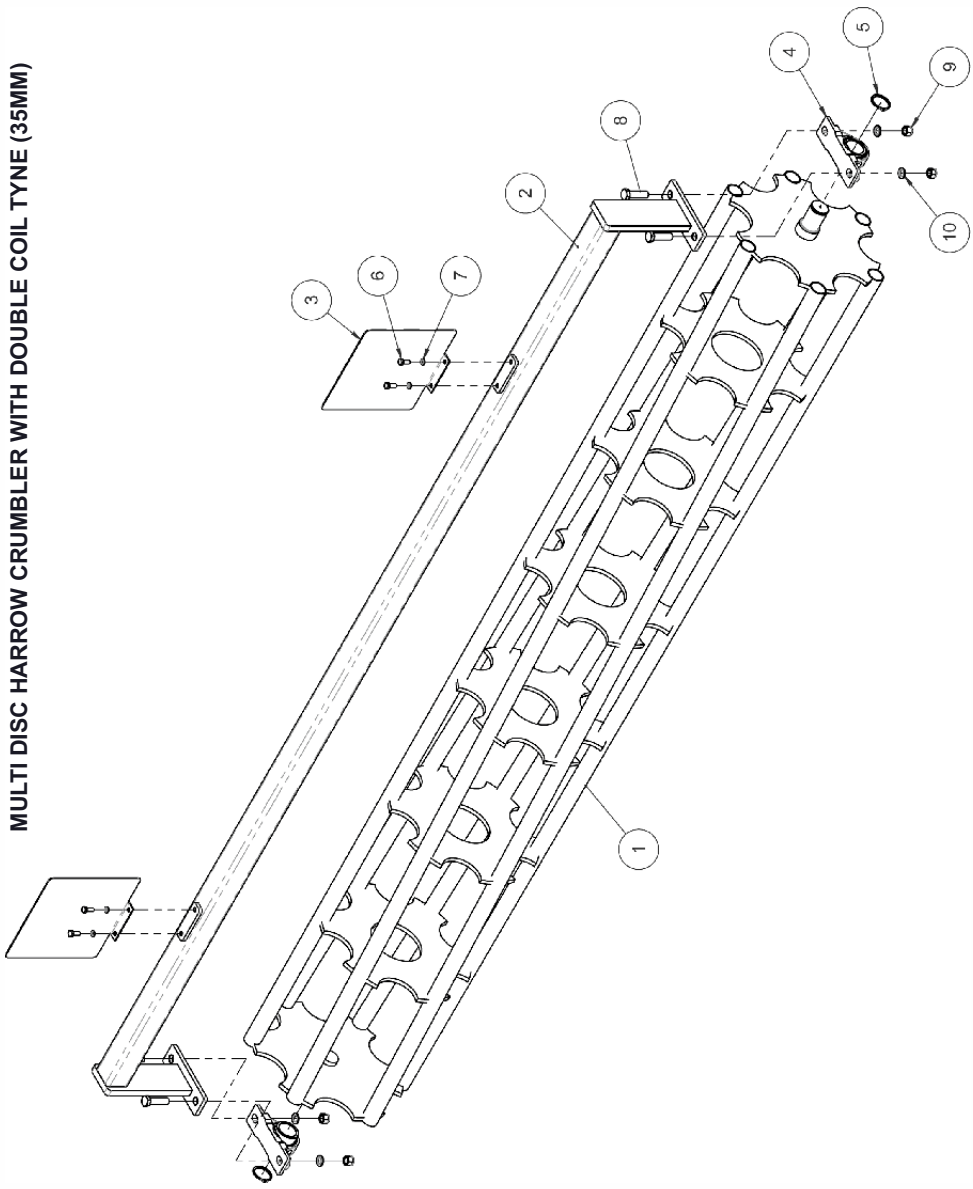

SR. NO.	PART NAME 12x12	PART NO.	QTY.
1	CRUMBLER ASSEMBLY (MULTI DISC HARROW)	79020018	1
2	CRUMBLER MOUNTING PIPE ASSEMBLY	79020036	1
3	REFLECTOR PLATE	79060001	2
4	AXLE HOUSING CRUMBLER	10050033	2
5	CIRCLIP EXTERNAL 50 A	10390010	2
6	HEX HEAD BOLT M10x1.5Px25L	10260361	4
7	SPRING WASHER 10MM	10270002	4
8	HEX HEAD BOLT M18x2.5Px65L	10260482	4
9	NYLOCK NUT M18x2.5P	10280020	4
10	SPRING WASHER 18MM	10270006	4

DELIVERY CHECKLIST

Dealer Pre-Delivery (Please Tick)	Please Complete all Dealer information Below
<p>1. Dealer Pre-Delivery Checklist</p> <ol style="list-style-type: none"> 1. The customer or person responsible has been given the operator's manual. 2. The customer undertakes to read the complete operator's manual and understands all aspects of the manual before operation of the machine. 3. All safety, operational and maintenance information have been explained and demonstrated. 4. All greasing and oil points, stickers, guarding and ID plate have been identified and physically pointed out. 5. The customer agrees that it is his responsibility to read and carry out the safety, maintenance and operation as per this operator's manual. 	<p>Dealer Information</p> <p>Dealer's Name.....</p> <p>Address.....</p> <p>State..... Postcode.....</p> <p>Phone..... Fax.....</p> <p>Email.....</p> <p>Service Person.....</p> <p>I confirm that the pre-delivery service was performed on this machine.</p> <p>Signature.....</p> <p>Date.....</p> <p>Comments.....</p>
Customer Delivery (Please Tick)	Please Complete all Customer Information Below
<p>2. Customer Delivery Checklist</p> <ol style="list-style-type: none"> 1. The customer or person responsible has been given the operator's manual. 2. The customer undertakes to read the complete operator's manual and understands all aspects of the manual before operation of the machine. 3. All safety, operational and maintenance information have been explained and demonstrated. 4. All greasing and oil points, stickers, guarding and ID plate have been identified and physically pointed out. 5. The customer agrees that it is his responsibility to read and carry out the safety, maintenance and operation as per this operator's manual. 	<p>Customer Information</p> <p>Customer's Name.....</p> <p>Address.....</p> <p>State..... Postcode.....</p> <p>Phone..... Fax.....</p> <p>Email.....</p> <p>Delivery Person.....</p> <p>I confirm that all of the delivery checks were explained and performed.</p> <p>Signature.....</p> <p>Delivery Date.....</p> <p>Comments.....</p>

FIELDKING

WARRANTY CARD Customer Copy

CUSTOMER NAME Mr./ Mrs. :

ADDRESS :

MOBILE NO. :

Email :

NAME OF IMPLEMENT :

MODEL NO. :

YEAR OF Mfg. :

SERIAL NO. :

REGISTRATION NO. :

DATE OF PURCHASING :

NAME OF DEALER :

Customer's Signature

Dealer's Signature



Beri Udyog Pvt. Ltd.

Corporate Office : Plot No. 235-236 & 238-240, Sec-3, HSIIDC,
 Karnal- 132001 (Haryana), India ☎ +91-184-2221571/ 72/ 73
 ✉ marketing@fieldking.com, exports@fieldking.com, 🌐 www.fieldking.com

FIELDKING

WARRANTY CARD Company Copy

CUSTOMER NAME Mr./ Mrs :

ADDRESS :

MOBILE NO. :

Email :

NAME OF IMPLEMENT :

MODEL NO. :

YEAR OF Mfg. :

SERIAL NO. :

REGISTRATION NO. :

DATE OF PURCHASING :

NAME OF DEALER :

Customer's Signature

Dealer's Signature



Beri Udyog Pvt. Ltd.

Corporate Office : Plot No. 235-236 & 238-240, Sec-3, HSIIDC,
Karnal- 132001 (Haryana), India ☎ +91-184-2221571/ 72/ 73

✉ marketing@fieldking.com, exports@fieldking.com, 🌐 www.fieldking.com

FIELDKING

WARRANTY CARD Dealer Copy

CUSTOMER NAME Mr./ Mrs :

ADDRESS :

MOBILE NO. :

Email :

NAME OF IMPLEMENT :

MODEL NO. :

YEAR OF Mfg. :

SERIAL NO. :

REGISTRATION NO. :

DATE OF PURCHASING :

NAME OF DEALER :

Customer's Signature

Dealer's Signature



Beri Udyog Pvt. Ltd.

Corporate Office : Plot No. 235-236 & 238-240, Sec-3, HSIIDC,
Karnal- 132001 (Haryana), India ☎ +91-184-2221571/ 72/ 73

✉ marketing@fieldking.com, exports@fieldking.com, 🌐 www.fieldking.com