

FIELDKING

Post Hole Digger



➤ [Operator Manual](#) ➤ [Service Manual](#) ➤ [Part Catalogue](#)

CONGRATULATIONS!

You have invested in one of the best implements of its type in the market today.

The care you give your "FIELDKING" implement will greatly determine your satisfaction with its performance and its service life. A careful study of this manual will give you a thorough understanding of your new implement before operating.

If your manual is lost or destroyed, "FIELDKING" will be glad to provide you a new copy. Visit to nearest dealership & get a copy. Most of our manuals can also be downloaded from our website at www.fieldking.com.

As an authorized "FIELDKING" dealer, we stock genuine "FIELDKING" parts which are manufactured with the same precision and skill as our original equipment. Our trained service persons are well informed on methods required to service "FIELDKING" equipments and are ready to help you.

Should you require additional information or assistance, please contact us.

YOUR AUTHORIZED

FIELDKING DEALER

BECAUSE "FIELDKING" MAINTAINS AN ONGOING PROGRAMME OF PRODUCT IMPROVEMENT, WE RESERVE THE RIGHT TO MAKE IMPROVEMENTS IN DESIGN OR CHANGE IN SPECIFICATION WITHOUT INCURRING ANY OBLIGATION TO INSTALL THEM ON UNITS PREVIOUSLY SOLD. BECAUSE OF THE POSSIBILITY THAT SOME PHOTOGRAPHS IN THIS MANUAL WERE TAKEN OF PROTOTYPE MODELS, PRODUCTION MODELS MAY VARY IN SOME DETAIL. IN ADDITION, SOME PHOTOGRAPHS MAY SHOW SHIELDS REMOVED FOR THE PURPOSE OF CLARITY. NEVER OPERATE THIS IMPLEMENT WITHOUT ALL SHIELDS IN PLACE.

TO THE PURCHASER

This manual contains valuable information about your new "FIELDKING" Post Hole Digger. It has been carefully prepared to give you helpful suggestions for operating, adjusting, servicing and ordering spare parts.

Keep this manual in a convenient place for quick and easy reference. Study it carefully. You have purchased a dependable and sturdy Post Hole Digger but only by proper care and operation you can expect to receive the service and long life designed and built into it.

Sometime in the future your Post Hole Digger may need new parts to replace which are worn out or broken. If so, go to your dealer and provide him equipment's detail like model and part number.

CUSTOMER INFORMATION

Name _____

Purchased From _____

Date of Purchase _____

Model No. _____

Serial No. _____

PURCHASER / OPERATOR'S RESPONSIBILITY

1. Read and understand the information contained in this manual.
2. Operate, lubricate, assemble and maintain the equipment in accordance with all instructions and safety procedures in this manual.
3. Inspect the equipment and replace or repair any parts that are damaged or worn out which under continued operation would cause damage, wear to other parts, or cause a safety hazard.
4. Return the equipment or parts to the authorized "FIELDKING" dealer, from where it was purchased, for service or replacement of defective parts that are covered by warranty. (The "FIELDKING" Factory may inspect equipment or parts before warranty claims are honored.)
5. All costs incurred by the dealer for traveling to or transporting the equipment for warranty inspection and claims will be borne by the customer.

INDEX

1. TECHNICAL DATA

- 1.1 Introduction
- 1.2 Warranty
- 1.3 When the warranty becomes void
- 1.4 Warning

2. USAGE INSTRUCTIONS

- 2.1 Before Use
- 2.2 Instructions for tractor preparation
- 2.3 Mounting of post hole digger to the tractor
- 2.4 Warning for driver
- 2.5 Operating instruction
- 2.6 Safety & equipment safety guideline

3. MAINTENANCE

- 3.1 Maintenance instructions
- 3.2 Storage of machine after work
- 3.3 Lubrication schedule
- 3.4 Trouble shooting

4. INSTRUCTION, PICTURES AND CODE NO FOR TRACTOR OPERATOR/ DRIVER

1. TECHNICAL DATA

1.1 INTRODUCTION

This handbook contains the use and maintenance instructions with a list of the spare parts of the post hole digger.

This Post Hole digger is equipped with heavy-duty rectangular pipe frame specially designed for deep digging / hole's for sugar cane, plantation etc.

Regular and satisfactory operations together with economic and long lasting use of the implement depend on the compliance with instructions given in this handbook.

Compliance with the instructions in this handbook is also important since manufacturer declines all and every responsibility for damage to persons or property caused by negligence and failure to comply with these instructions.

1.2 WARRANTY

When the implement is delivered, check that it has not been subjected to damage during transport and that the accessories are in a perfect condition and complete.

Any claims following the receipt of damaged goods shall be presented in writing within 8 days from the receipt of the goods.

The purchaser may only make the claims under warranty. When he has complied with the warranty conditions in the supply contract.

1.3 WHEN THE WARRANTY BECOMES VOID

Besides the cases specified in the supply agreement, the guarantee shall in any case become void.

1. When the implement has been used beyond the specified power limit like (Tractor Horse Power)
2. When repairs made by the customer without authorization from the manufacturer or owing to installation of spurious spare parts, the machine is subjected to variations and the damage can be ascribed to these variations.
3. When the user has failed to comply with the instructions in this handbook.
4. If the implement is used in very hard/stony soil no warranty of blade & Auger will be entertained.
5. If the implement is not lifted while steering forward or backward, no warranty of any breakage of auger would be entertained.
6. No warranty will be given if the service and greasing is not done on time.

1.4 WARNING

Thoroughly read the instruction manual before proceeding with the various operations.

Maintain the post hole digger as per the instruction of this hand book to be entitled for warranty.

2. USAGE INSTRUCTIONS

2.1 BEFORE USE & ADJUSTMENT

- 1) Before mounting of post hole digger make sure that all nuts and bolts are properly secured.
- 2) Adjust spring loaded shocker to keep auger perpendicular to ground while digging and control swinging while transportation or moving from one point to another.

2.2 INSTRUCTION FOR TRACTOR PREPARATION

The following are typical instructions for preparing a tractor for operation.

1. The horsepower of tractor selected should match the implement.
2. Provide adequate front end ballast for tractor stability.
3. Provide proper rear furrow wheel weight.
4. All post hole digger adjustment should be carried out.
5. Select load and depth control setting according to tractor operators manual.

2.3 MOUNTING OF POST HOLE DIGGER TO THE TRACTOR

1. Attach arch to lower hitch points. If tractor has category 2 hitch, use bushing's provided on arch pins.
2. Attach arch to boom with pin and cotter pins provided.
3. Attach gearbox to boom with pins and cotter pins provided.
4. Attach PTO shield to top of gearbox with bolts provided.
5. Prepare PTO for attachment.
 - a. Remove any foreign material or paint from input shaft on gearbox.
 - b. Separate PTO driveshaft. Use a good grade of gun grease and put a light coat on U-joint drive shaft. Then insert into drive tube.
 - c. Attach PTO to gearbox.
 - d. Make sure roll pin is in groove of input shaft but not tight against bottom of groove so yoke will rotate freely.
 - e. Put in shear bolt.
 - f. Place snap yoke on tractor PTO.

- g. Raise and lower the boom through it's complete operation arch and check that nothing interferes with the operation. If anything interferes, make the proper three-point adjustments.
6. Attach the output shaft shield to lower gearbox.
7. Attach the auger to gearbox using bolts, lock washers and hex nuts provided.

2.4 WARNING FOR DRIVER

1. When Post hole digger is ready for use don't move the tractor forward & backward.
2. Properly fit the arch complete & lock with lynch pin.
3. Before working check all nut & bolt's of the Post hole digger.
4. Before using do greasing at required places .
5. After it is used the implement clean it properly.

2.5 OPERATING INSTRUCTIONS

1. Lower auger point slowly to ground. Auger point should be about 4" to the rear of the plumb line of the center of the top of the auger.
2. Set brake or use Park position.
3. Engage PTO shaft clutch at half throttle and slowly lower auger into ground. In some types of soil it may be necessary to hold auger back from screwing itself into the ground with the hydraulic control lever.
4. In some types of soil, for best cleaning action, allow auger to dig a foot or so and raise auger almost out of the ground and then dig deeper. Repeat as necessary.
5. When auger has reached the desired depth, leave auger at this depth for a very short period to assist in cleaning out the hole.
6. If shear bolt shears, replace with Manufacturers shear bolt or with one with the same specifications Grade 2 bolt.
7. If auger becomes lodged below the ground, Do not attempt to lift auger out of ground by hydraulic lift power alone. Reverse the rotation of the auger by several turns. This can be accomplished by using a bar on the universal joints. After freeing the auger, slowly lift with auger slowly rotating.
8. Do not transport digger with PTO shaft engaged. This may result in damage to universal joints.
9. Check post hole digger daily for any damaged or loose bolts, securing pins, etc.

2.6 SAFETY & EQUIPMENT SAFETY GUIDELINE

SAFETY

Read & follow the instruction in this manual & specially in the safety section failure to do so can result in serious injury or death.

TAKE NOTE!

This is safety alert symbol found throughout this manual which is used to call your attention to introductions involving your personal safety & the safety of other's.



DANGER

Indicates an immediate hazardous situation that, if not avoided, could result in serious injury or death. This signal word is to be limited to the most extreme situations typically for machine components that, for functional purposes, cannot be guarded.

WARNING

Indicates a potentially hazardous situation that, if not avoided, could result in serious injury or death and includes hazards that are exposed when guards are removed. It may also be used to alert against unsafe practices.

CAUTION

Indicates a potentially hazardous situation that, if not avoided, may result in minor or moderate injury. It may also be used to alert against unsafe practice.

If you have any questions not answered in this manual or require additional information / copies or the manual is damaged, please contact your dealer or "FIELDKING" or www.fieldking.com

1. This post hole digger was designed for one-man operation from the tractor seat. It is the responsibility of the operator to see that no one is within twenty-five feet (25') of the digger when it is started. Do not operate the digger with another person near, or in contact with, any part of the digger, PTO driveline, or auger. Serious personal injury or death may result if any attempt is made to assist digger operation by hand.
2. If a safety shield or guard is removed for any reason, it must be replaced before the machine is again operated. Always use, and maintain in place, all power take off guards furnished with the tractor as well as the power take off guards and shields furnished with the digger.
3. This digger is designed for use only on tractors with 540 RPM power take off.
4. When driving the tractor and equipment on the road or highway under 20 mph (32 kph) at night or during the day, use flashing amber warning lights and a slow moving vehicle (SMV) identification emblem.
5. Good maintenance is your responsibility. Poor maintenance is an invitation to trouble.
6. Before working on this machine, drive to a level area, disengage the PTO, lower implement (or if working underneath, raise and block securely), shut off the engine, set the brakes, and remove the ignition keys.

7. The signal words DANGER, WARNING and CAUTION are used with the safety messages in this manual and with each safety signs. They are defined as follow.

EQUIPMENT SAFETY GUIDELINES

- 1) Safety of the operator and by standers is one of the main concerns in designing and developing a digger. However, every year accidents occur which could have been avoided by a few seconds of thought and a more careful approach to handling equipment. You, the operator, can avoid many accidents by adopting the following precautions and insist those working with you, or for you, follow them.
- 2) In order to provide a better view, certain photographs or illustrations in this manual may show an assembly with a safety shield removed. However, equipment should never be operated in this condition. Keep all shields in place. If cover removal becomes necessary for repairs, replace the shield prior to use.
- 3) Replace any safety sign that is not readable or is missing. Copies of such safety signs is shown in this manual.
- 4) Never use alcoholic beverages or drugs that can hinder alertness or coordination while operating this equipment. Consult your doctor about operating this machine while taking prescribed medications.
- 5) Under no circumstances should children under the age of 18 be allowed to work with this equipment. Do not allow persons to operate or assemble this unit until they have read this manual and have developed a thorough understanding of the safety precautions and of how it works. Review the safety instructions with all users annually.
- 6) This equipment is dangerous to children and persons unfamiliar with its operation. The operator should be a responsible, properly trained and physically able person familiar with farm machinery and trained in this equipment's operations. If the elderly are assisting with farm work, their physical limitations need to be recognized and accommodated.
- 7) Never exceed the limits of a piece of machinery. If its ability to do a job, or to do so safely, is in question- Don't try it.
- 8) Do not modify the equipment in any way. Unauthorized modification could result in serious injury or death of operator or may impair the function and life of the equipment.
- 9) In addition to the design and the configuration of this implement, including safety signs and safety equipment, hazard control and accident prevention are dependent upon the awareness, concern, prudence, and proper training of

personnel involved in the operation, transport, maintenance and storage of the machine. Also refer to safety messages and operating instruction in each of the appropriate sections of the tractor and post hole digger manuals. Pay close attention to the safety signs affixed to the tractor and the post hole digger.

SAFETY SIGN/SYMBOLS LOCATIONS

- The types of safety signs and locations on the equipment are shown in the illustration below. Good safety requires that you familiarize yourself with the various safety signs, the type of warning and the area, or particular function related to that area, that requires your safety awareness.



In order to protect yourself always wear adequate clothes and shoes during the operations.



Never allow riders on the tractor or implement unless an additional seat is available.



Be careful when moving around steep gradient to avoid sharp turn.

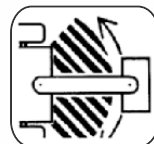

Never transport the implement on rough roads during the night. When operating, avoid sharp turns that may cause tractor colliding with the implement.

3. MAINTENANCE

3.1 MAINTENANCE INSTRUCTIONS

If you use the post hole digger on stony land then maintenance also increases. please follow these rules to get the best results.

1. If post hole digger is new then after first two hours of working tightened all nut bolts.
2. Check the post hole digger adjustments if the steering is hard.
3. After every fifty hours grease all greasing points with grease gun and tighten all nuts and bolts.

4. After 250 hundred hours, change the gearbox lubrication oil.
5. Constantly check for loose nuts and bolts.
6. Sharpen the blade if the blades are dull. Blunt blades increase the load considerably.
7. Keep the bearings lubricated as per the instructions given in the manual.

3.2 STORAGE OF MACHINE AFTER WORK

1. Wash the Post hole digger after work
2. Replace the worn out nuts and bolts.
3. If Post hole digger has to remain unused for long time then clean it & apply a layer of used oil for rust prevention.

3.3 LUBRICATION SCHEDULE

1. Fill the post hole digger gearbox with SAE 140 EP oil and check periodically to maintain correct oil level.
2. After the first fifty (50) hours it is recommended that the gearbox be drained, flushed and refilled with SAE 140 EP oil. Then every 250 hours.
3. Universal joints to be greased after digging 100 holes. Tube and shaft should be greased every other time.

3.4 TROUBLE SHOOTING

At the end of the season:

1. Drain and change the oil in your gearbox.
2. Check and replace, where necessary, blades, bolts, nuts on the machine.
3. Clean machine and touch up any rust spots that may have appeared.
4. Replace any safety signs if damaged or painted over.
5. Make sure PTO driveline yoke and gearbox input shaft are clean and free of burrs. Keep well lubricated to prevent galling of yoke and input shaft when shear bolt becomes sheared.
6. Keep all shields in place. Order new shields if damaged or missing.
7. Keep cutting edges sharp. Sharp cutting edges dig easier and better. Outer cutting edges on larger augers wear faster than inner cutting edges; switching teeth will even wear.
8. Store implement in clean, dry location, away from children, animals, or traffic area.

PROBLEM

Possible Solutions

AUGER WILL NOT DIG

1. Shear bolt sheared — install new shear bolt.
2. Teeth dull — sharpen or replace.

3. Ground too dry and hard — order optional down force kit, or wait until it rains. (May have to replace center point.)
4. Auger turning too fast and bouncing — reduce speed.
5. Tall grass has wrapped around auger teeth — remove.
6. Auger encountering rocks, roots or other obstruction — lift auger from hole and inspect.
7. Auger teeth improperly positioned — see operator's manual for proper tooth pattern.

AUGER DIGS SO FAR, BUT WILL NOT DIG DEEPER

1. See solutions for above.
2. PTO assembly "bottoms out" not allowing digger to lower — remove auger from digger and lower digger. Gearbox should lower to the ground; if not, PTO driveline assembly may need to be shortened.
4. PTO driveline interferes with swinging drawbar — swing drawbar out of the way or remove.
5. Tractor hydraulic system may be faulty — consult tractor dealer.
6. Soil could have hardpan layer 6"-10" below surface — use optional down force kit (see list of optional equipment).

POST HOLE DIGGER SWAYS SIDE TO SIDE

1. No sway bars or sway blocks on tractor — add same.
2. Lift arms not adjusted evenly — adjust lift arms.
3. Post hole digger is mounted with excessive looseness in the hitch connecting points — use proper size pins or bushings.

BENT AUGER FLIGHTING OR BENT AUGER

1. Tractor moved while auger was turning in hole — always set brakes on tractor and make sure it is out of gear.
2. Operator moved tractor with auger in hole to try and straighten a hole being dug at an angle.
3. Auger is encountering rocks or roots or other foreign objects — remove object from hole or change location.
4. Outer edge of auger flighting is bending due to contact with rocks or roots — use heavy duty auger with thicker flighting.
5. Shear bolt has been replaced with harder bolt — replace with Grade 2 bolt per instructions.

AUGER SCREWS ITSELF INTO THE GROUND

1. Operator did NOT ease 3-pt. hitch to ground slowly.
2. Faulty 3-pt. hitch hydraulic system on tractor.

3. Draft control is not in OFF position.
4. Tractor is too small to handle digger.

EXCESSIVE VIBRATION

1. PTO driveline bearing cross is worn — replace.

PTO DRIVELINE ASSEMBLY COMES OFF INPUT SHAFT OF GEARBOX WHEN SHEAR BOLT IS SHEARED.

1. Roll pin missing in yoke at gearbox input shaft. Install roll pin as per instructions.

Warning: this is a dangerous safety hazard, Correct immediately!

PTO DRIVELINE FAILURE

1. Operator raising post hole digger too high above ground when PTO is engaged — causes excessive PTO joint operating angle.
2. PTO is engaged while moving between holes. (Auger swings, which causes excessive PTO joint operating angle.)
3. Improper use of a hard shear bolt — use Grade 2 bolt per instructions.
4. Driveline has not been properly lubricated.
5. Engaging tractor PTO with engine at high rpm.
6. Digging holes too deep so that PTO driveline contacts ground.
7. Operating at high rpm.
8. Use of auger extension can require post hole digger to be lifted high, which can cause excessive PTO joint operating angle.
9. Tractor is a “low profile model” (one that is low to the ground). Due to the low height of the tractor, the digger must be raised higher to have the bottom of the auger clear the ground. Generally, low profile model tractors can only use 30 inch long augers (standard auger length is 42"). Use a different tractor or purchase 30" long augers.

TRACTOR STALLS

1. Auger is encountering rocks or roots or other foreign object — remove object or change hole location.
2. Tractor idle is not set correctly — tune tractor engine.

GEARBOX FAILURE

1. No oil in gearbox.
2. Oil not changed per instructions.
3. Shear bolt has been replaced with a harder bolt — replace with Grade 2 per instructions.

4. Bent output shaft is due to operator moving tractor when auger is in hole.

GEARBOX OVERHEATING

1. Low on lubricant — fill to proper level.
2. Improper type lubricant — replace with proper lubricant.
3. Check breather valve.

AUGER BOLTS SHEAR ON GEARBOX OUTPUT SHAFT

1. Shear bolt on input shaft has been replaced with a harder bolt — replace with Grade 2 bolt as per instructions.

PTO DRIVELINE “GALLS” OR “FRICTION WELDS” TO INPUT SHAFT OF GEARBOX

1. No lubrication on input shaft of gearbox to allow yoke of PTO driveline to turn freely on input shaft when shear bolt is sheared. Always keep input shaft greased.
2. Implement end yoke and gearbox input pinion may have to be replaced.

AUGER SWINGING WHEN DIG

1. Adjust spring loaded shocker to dig straighten.

ADJUSTING ROD ASSEMBLY

Simply stated, adjusting rod assembly is used for straightness of auger at the time of operation. With the help of adjusting rod provided on adjusting pipe we can adjust the straight position of auger before operation.

The advantages are:

- Straightness
- Drift and Depth of Hole
- Close Tolerance of Hole
- Surface Finish
- Productivity
- Unique Capabilities.

POST HOLE DIGGER

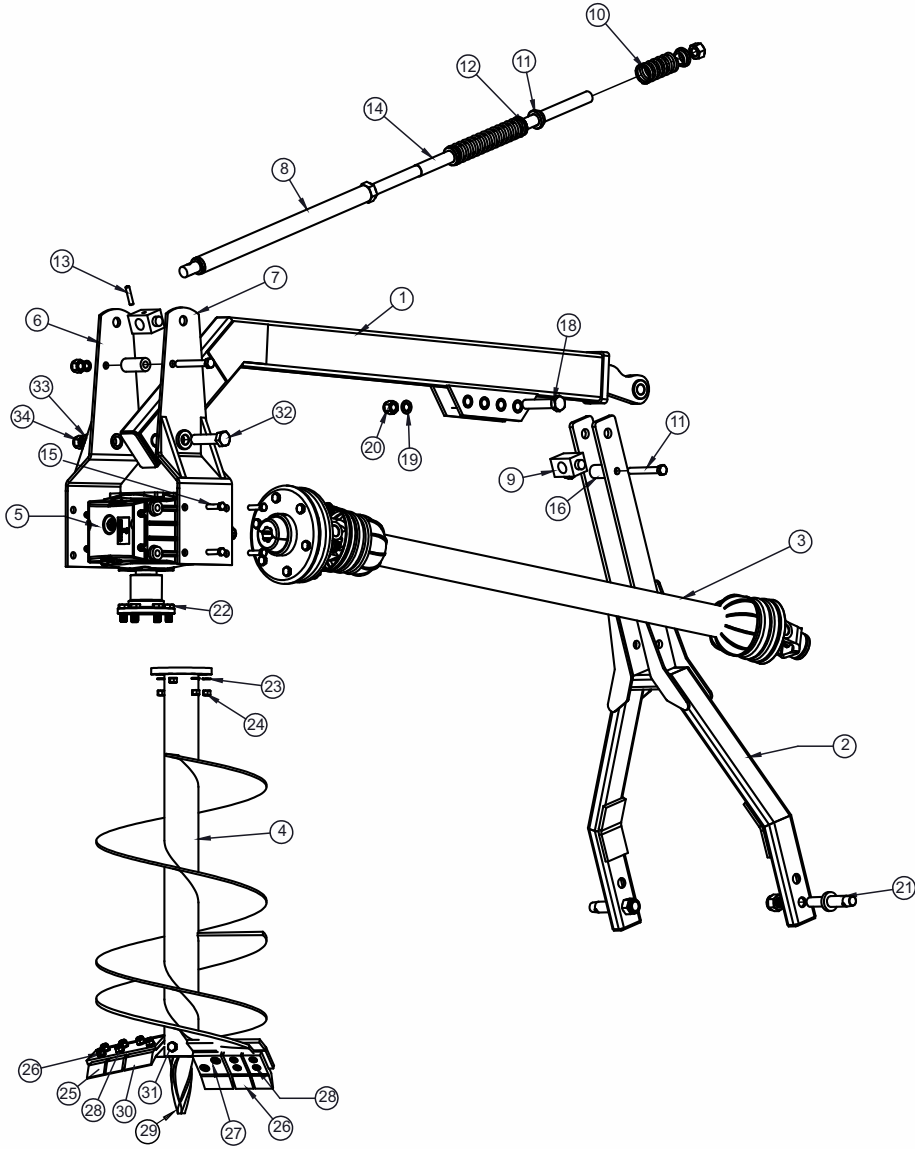

SL. NO.	PART NAME	PART NO.				QTY.			
		AUGER-6" 98010027	AUGER-9" 98010025	AUGER-12" 98010026	AUGER-18" 98010024	AUGER-6" 98010027	AUGER-9" 98010025	AUGER-12" 98010026	AUGER-18" 98010024
1	BOOM COMPLETE ASSEMBLY		75050014						1
2	ARCH COMPLETE ASSEMBLY		75060008						1
3	PTO SHAFT		10310038						1
4	AUGER ASSEMBLY	71670002	71670003	71670004	71670015				1
5	GEAR BOX		78750059						1
6	GEARBOX MOUNTING PLATE ASSY-LHS		75050023						1
7	GEARBOX MOUNTING PLATE ASSY-RHS		75050024						1
8	ADJUSTING ROD ASSY.		75060015						1
9	SQUARE BUSH		75060013						2
10	POST HOLE DIGGER SPRING SMALL (WIRE DIA 7 X 108L)		10210022						1
11	SPRING CONE		75060019						1
12	POST HOLE DIGGER SPRING BIG (WIRE DA 7 X 252L)		10210021						1
13	DOWEL PIN 10X65		10210028						1
14	ADJUSTING ROD		75060018						1
15	HEX HEAD BOLT M16X50X2MM		10260358						8
16	BOOM MOUNTING RATE BUSH		75060014						1
17	SPRING WASHER 10MM		10270002						1
18	HEX HEAD BOLT M20X130X2.5MM (10.9)		10260451						1
19	SPRING WASHER 20MM		10270016						1
20	NYLOCK NUT M20X2.5MM		10280021						1
21	HITCH PIN 36X167MM		10020024						1
22	HEX HEAD BOLT M12X50X2MM (8.8)		10260363						6
23	SPRING WASHER 12MM		10270003						6
24	NYLOCK NUT M12X1.75MM		10280025						6
25	AUGER BLADE SMALL		71670008						2
26	NYLOCK NUT M12X1.75		10280025						7
27	CSK BOLT M12X40X1.75MM		10260052						4
28	SPRING WASHER 12MM		10270003						7
29	AUGER TIP		71670006						1
30	AUGER BLADE BIG		71670007						2
31	HEX HEAD BOLT		10260374	10260288					1
32	HEX HEAD BOLT M24X130X3P (8.8)		10260416						1
33	SPRING WASHER 24MM		10270027						1
34	NYLOCK NUT M24X3P		10280075						1

POST HOLE DIGGER GEAR BOX

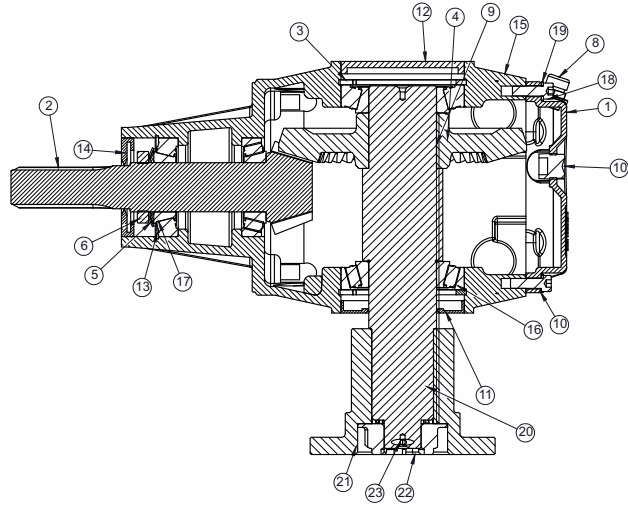

DELIVERY CHECKLIST

SR. NO.	PART NAME	PART NO.	QTY.
1	GEAR BOX COVER	10150038	1
2	BEVEL PINION 12T	101250079	1
3	CIRCLIP 100MM	10390007	2
4	BEVEL GEAR 36T	10250078	1
5	LOCK WASHER M40	10270046	1
6	LOCK NUT M40X1.5P	10280103	1
7	DRAIN PLUG M16X1.5P	10190014	1
8	BREATHER VALVE	10190013	1
9	PARRALEL KEY	10030018	1
10	OIL LEVEL INDICATOR	10300117	1
11	OIL SEAL 55x100x10	10010047	1
12	OIL SEAL RCA 100x10	10010092	1
13	INTERNAL CIRCLIP B80, 2.5 MM. THICK	10390005	1
14	OIL SEAL 35x80x10/7	10010062	1
15	GEAR BOX HOUSING	10080015	1
16	BEARING 30211	10050050	2
17	BEARING 32208	10050021	2
18	ALLEN KEY BOLT M8X25X1.25 (P)	10260433	6
19	SPRING WASHER 8MM	10270001	6
20	MAIN SHAFT	10290079	1
21	GEAR BOX BOTTOM FLANGE	10230028	1
22	CASTLE NUT M30x1.5P	10280093	1
23	SPLIT PIN 4MMX65MM (L)	10020055	1

Dealer Pre-Delivery (Please Tick)
<p>1. Dealer Pre-Delivery Checklist</p> <ol style="list-style-type: none"> The customer or person responsible has been given the operator's manual. The customer undertakes to read the complete operator's manual and understands all aspects of the manual before operation of the machine. All safety, operational and maintenance information have been explained and demonstrated. All greasing and oil points, stickers, guarding and ID plate have been identified and physically pointed out. The customer agrees that it is his responsibility to read and carry out the safety, maintenance and operation as per this operator's manual.
Customer Delivery (Please Tick)
<p>2. Customer Delivery Checklist</p> <ol style="list-style-type: none"> The customer or person responsible has been given the operator's manual. The customer undertakes to read the complete operator's manual and understands all aspects of the manual before operation of the machine. All safety, operational and maintenance information have been explained and demonstrated. All greasing and oil points, stickers, guarding and ID plate have been identified and physically pointed out. The customer agrees that it is his responsibility to read and carry out the safety, maintenance and operation as per this operator's manual.

Please Complete all Dealer information Below
<p>Dealer Information</p> <p>Dealer's Name.....</p> <p>Address.....</p> <p>State..... Postcode.....</p> <p>Phone..... Fax.....</p> <p>Email.....</p> <p>Service Person.....</p> <p>I confirm that the pre-delivery service was performed on this machine.</p> <p>Signature.....</p> <p>Date.....</p> <p>Comments.....</p>
Please Complete all Customer Information Below
<p>Customer Information</p> <p>Customer's Name.....</p> <p>Address.....</p> <p>State..... Postcode.....</p> <p>Phone..... Fax.....</p> <p>Email.....</p> <p>Delivery Person.....</p> <p>I confirm that all of the delivery checks were explained and performed.</p> <p>Signature.....</p> <p>Delivery Date.....</p> <p>Comments.....</p>

FIELDKING

WARRANTY CARD Customer Copy

CUSTOMER NAME Mr./ Mrs :

ADDRESS :

MOBILE NO. :

Email :

NAME OF IMPLEMENT :

MODEL NO. :

YEAR OF Mfg. :

SERIAL NO. :

REGISTRATION NO. :

DATE OF PURCHASING :

NAME OF DEALER :

Customer's Signature

Dealer's Signature



Beri Udyog Pvt. Ltd.

Corporate Office : Plot No. 235-236 & 238-240, Sec-3, HSIIDC,
Karnal- 132001 (Haryana), India ☎ +91-184-2221571/ 72/ 73

✉ marketing@fieldking.com, exports@fieldking.com, 🌐 www.fieldking.com

FIELDKING

WARRANTY CARD Company Copy

CUSTOMER NAME Mr./ Mrs :

ADDRESS :

MOBILE NO. :

Email :

NAME OF IMPLEMENT :

MODEL NO. :

YEAR OF Mfg. :

SERIAL NO. :

REGISTRATION NO. :

DATE OF PURCHASING :

NAME OF DEALER :

Customer's Signature

Dealer's Signature



Beri Udyog Pvt. Ltd.

Corporate Office : Plot No. 235-236 & 238-240, Sec-3, HSIIDC,
Karnal- 132001 (Haryana), India ☎ +91-184-2221571/ 72/ 73

✉ marketing@fieldking.com, exports@fieldking.com, 🌐 www.fieldking.com

FIELDKING

WARRANTY CARD

Dealer Copy

CUSTOMER NAME Mr./ Mrs :

ADDRESS :

MOBILE NO. :

Email :

NAME OF IMPLEMENT :

MODEL NO. :

YEAR OF Mfg. :

SERIAL NO. :

REGISTRATION NO. :

DATE OF PURCHASING :

NAME OF DEALER :

Customer's Signature

Dealer's Signature



Beri Udyog Pvt. Ltd.

Corporate Office : Plot No. 235-236 & 238-240, Sec-3, HSIIDC,

Karnal- 132001 (Haryana), India ☎ +91-184-2221571/ 72/ 73

✉ marketing@fieldking.com, exports@fieldking.com, 🌐 www.fieldking.com