

FIELDKING

Side Shifting Rotary Tiller



➤ [Operator Manual](#) ➤ [Service Manual](#) ➤ [Part Catalogue](#)

CONGRATULATIONS!

You have invested in one of the best implements of its type in the market today.

The care you give your "FIELDKING" implement will greatly determine your satisfaction with its performance and its service life. A careful study of this manual will give you a thorough understanding of your new implement before operating.

If your manual is lost or destroyed, "FIELDKING" will be glad to provide you a new copy. Visit to nearest dealership & get a copy. Most of our manuals can also be downloaded from our website at www.fieldking.com.

As an authorized "FIELDKING" dealer, we stock genuine "FIELDKING" parts which are manufactured with the same precision and skill as our original equipment. Our trained service persons are well informed on methods required to service "FIELDKING" equipments and are ready to help you.

Should you require additional information or assistance, please contact us.

YOUR AUTHORIZED

FIELDKING DEALER

BECAUSE "FIELDKING" MAINTAINS AN ONGOING PROGRAMME OF PRODUCT IMPROVEMENT, WE RESERVE THE RIGHT TO MAKE IMPROVEMENTS IN DESIGN OR CHANGE IN SPECIFICATION WITHOUT INCURRING ANY OBLIGATION TO INSTALL THEM ON UNITS PREVIOUSLY SOLD. BECAUSE OF THE POSSIBILITY THAT SOME PHOTOGRAPHS IN THIS MANUAL WERE TAKEN OF PROTOTYPE MODELS, PRODUCTION MODELS MAY VARY IN SOME DETAIL. IN ADDITION, SOME PHOTOGRAPHS MAY SHOW SHIELDS REMOVED FOR THE PURPOSE OF CLARITY. NEVER OPERATE THIS IMPLEMENT WITHOUT ALL SHIELDS IN PLACE.

TO THE PURCHASER

This manual contains valuable information about your new "FIELDKING" Side Shifting Rotary Tiller. It has been carefully prepared to give you helpful suggestions for operating, adjusting, servicing and ordering spare parts.

Keep this manual in a convenient place for quick and easy reference. Study it carefully. You have purchased a dependable and sturdy Side Shifting Rotary Tiller but only by proper care and operation you can expect to receive the service and long life designed and built into it.

Sometime in the future your Side Shifting Rotary Tiller may need new parts to replace which are worn out or broken. If so, go to your dealer and provide him equipment's detail like model and part number.

CUSTOMER INFORMATION

Name _____

Purchased From _____

Date of Purchase _____

Model No. _____

Serial No. _____

PURCHASER / OPERATOR'S RESPONSIBILITY

1. Read and understand the information contained in this manual.
2. Operate, lubricate, assemble and maintain the equipment in accordance with all instructions and safety procedures in this manual.
3. Inspect the equipment and replace or repair any parts that are damaged or worn out which under continued operation would cause damage, wear to other parts, or cause a safety hazard.
4. Return the equipment or parts to the authorized "FIELDKING" dealer, from where it was purchased, for service or replacement of defective parts that are covered by warranty. (The "FIELDKING" Factory may inspect equipment or parts before warranty claims are honored.)
5. All costs incurred by the dealer for traveling to or transporting the equipment for warranty inspection and claims will be borne by the customer.

INDEX

1. TECHNICAL DATA

- 1.1 Introduction
- 1.2 Warning signal
- 1.3 Danger signal
- 1.4 Personal protective equipment
- 1.5 Equipment safety guidelines
- 1.6 Indicator signal
- 1.7 Identification

2. SAFETY AND ACCIDENT PREVENTIONS

3. INSTRUCTIONS FOR OPERATOR

- 3.1 Machines supplied partly broken-down
- 3.2 Before use
- 3.3 Hitching to the tractor
- 3.4 Cardan shaft
- 3.5 Working depth
- 3.6 Chain tensioner
- 3.7 Hoe blades
- 3.8 In working
- 3.9 How it works
- 3.10 Troubleshooting hints for the tractor operator
- 3.11 Parking

4. MAINTENANCE

- 4.1 Every 8 work hours
- 4.2 Every 50 work hours
- 4.3 Every 200 work hours
- 4.4 Storage
- 4.5 Lubrication

5. SERVICING TIPS

Parts Catalogue

NOTE:

BERI UDYOG PVT. LTD reserves the right to modify machine design and specifications provided herein without any preliminary notice. Information provided herein is of descriptive nature. Performance quality may depend on soil quality.

1. TECHNICAL DATA

1.1 INTRODUCTION

This handbook contains operating and maintenance instructions plus a list of the parts supplied as spare parts for the rotary tiller.

Rotary Tiller can only operate by means of a **cardan shaft** engaged to the PTO of an agricultural tractor equipped with lift and universal three point hitch.

Besides working the soil in open areas, the particular and specific design of this implement makes it ideal for working between the rows of orchards and vineyards etc. Regular and satisfactory operations together with economic and long lasting use of the implement depend on the compliance with the instructions given in this handbook. It is therefore advisable to strictly comply with the following instructions in order to prevent faults that could jeopardize the correct and long lasting operation of the implement.

Compliance with the instructions in this handbook is also important though **manufacturer declines all and every responsibility for damage to persons or property caused by negligence and failure to comply with these instructions.**

The manufacturer shall, however, remain at the customer's disposal for immediate and thorough assistance together with anything else that may be required in order to ensure the correct operation and maximum efficiency of the implement.

1.2 WARNING SIGNAL

REMEMBER SAFETY FIRST

Operator must read the instruction manual before operating the rotary tiller. Do not allow anyone to operate this equipment who has not fully read and comprehended this manual and who has not been properly trained in the safe operation of the equipment.



1.3 DANGER SIGNAL

1. Sharp objects could be thrown up keep a safe distance from the rotary tiller.
2. Risk of injury to leg
3. Keep away from the moving parts. Never remove guards while working.
4. Your implement is not designed to carry passengers - NO RIDER
5. Never allow anyone to stand between the tractor and implement while an operator is backing up to the implement.
6. Keep away from the cardan shaft. Keep away from the moving parts.



1.4 PERSONAL PROTECTIVE EQUIPMENT



1. Do not wear loose fitting dress, dangling jewellery. Long hair should be tied back to avoid entangling.
2. Wear appropriate footwear. Soft cloth shoes or sandals are not safe around any type of equipment.
3. Wear hearing protection such as earplugs or other devices that will minimize sounds. But will not interfere with your ability to hear traffic or other noises that may alert you to potential hazards.
4. Do not operate any machinery while talking on a cell phone or other portable devices such as MP3 players, as these are considered distractions- operating any farm equipment requires the operator's full attention.

1.5 EQUIPMENT SAFETY GUIDELINES



1. Read safety instructions for both the tractor and this tiller before use.
2. Never exceed the advised limits of the tractor or the tiller.
3. This equipment is dangerous to children and those unfamiliar with its operation. DO NOT ALLOW children to operate or play around equipment.
4. Operator should be an adult who is familiar with operating the tractor and the tiller.

Operator should be physically and mentally fit before operating machinery. Fatigue, stress, alcohol and drugs may impair the ability for safe farm machinery operation.

1.6 INDICATOR SIGNALS

1. Coupling point for lifting (Indicating the maximum capacity)
2. Oil fill plug.
3. Oil drain Plug.
4. Oil Level Plug.
5. Greasing point.
6. Identification Plate.

1.7 IDENTIFICATION

Each individual rotary tiller has an identification plate indicating the following details, which should be copied into the handbook along with the date of purchase:

1. Machine type.
2. Machine model.
3. Serial number.
4. Year of manufacture.

2. SAFETY AND ACCIDENT PREVENTION

Pay great attention to the danger signal indicated in this handbook. There are three types of danger signals:

Danger: This signal warns for serious injuries, death or long-term health risks would be caused by failure to correctly carry out the described operations.

Warning: This signal warns for serious injuries, death or long-term health risks that can be caused by failure to correctly carry out the described operations.

Caution: This signal warns for damage to the machine could be caused by failure to carry out the described operations.

Thoroughly read all the instructions before using the rotary tiller. Contact the technicians of your authorized dealer in case of doubt. The manufacturer declines all and every responsibility for injury/accidents in event of non-compliance of following safety and accident preventing provisions.

- 1) Comply with the instructions given by the danger symbols in this handbook and affixed to the steerage hoe itself.
- 2) Never touch any moving part.
- 3) Minor maintenance and adjustments to the rotary tiller must always be carried out when the engine is off and the tractor braked.
- 4) It is absolutely forbidden to carry passengers or any animals on the rotary tiller.
- 5) It is absolutely forbidden for a person without a driving license, untrained person or those in precarious health conditions to drive the tractor with the rotary tiller mounted.
- 6) Strictly comply with all the recommended accident preventing measures described in this handbook.
- 7) Assembly of a rotary tiller on the tractor will shift the weights on the axles. It is therefore advisable to add weights to the front part of the tractor in order to balance the weights on the axles themselves.
- 8) The coupled implement may only be controlled through the cardan shaft complete with the necessary safety devices for overloads and with the appropriate chains. Keep away from the cardan shaft while it is turning.
- 9) Before starting the tractor and implement, always check that all safety devices guarding transport and use are in perfect conditions.
- 10) The instruction labels affixed to the machine give useful advice on how to prevent accidents.
- 11) Always comply with the Highway Code in force in your country, when travelling on public roads.
- 12) Comply with the maximum permissible weight on the axle of the tractor, the total adjustable weight, transport regulations and the highway code.
- 13) Always be familiar with the controls and their operation before starting to work.
- 14) Avoid sharp turns as this may cause implement to ride up on the tractor's wheels and might result in serious injury and damage to your equipment.
- 15) As indicated, couple the implement to a tractor of adequate power and configuration, using a device (lift) conforming to the precautions.
- 16) Take the utmost care during the implement coupling and release phases.
- 17) Any accessories for transport must be equipped with adequate signals and guards.
- 18) Never leave the driving seat while the tractor is moving.
- 19) It is very important to remember that the road holding, steering and braking capacity may be notably influenced by the presence of towed or mounted implement.
- 20) Always take care of the centrifugal force exercised by the position of the center of gravity, when turning corners with the implement mounted.
- 21) Before engaging the PTO, check that the rpm rate is the same as prescribed. Never exchange the 540-rpm rate for 1000-rpm or vice versa.
- 22) It is absolutely forbidden to stand within the operative range of the machine where there are moving parts.
- 23) Before leaving the tractor, lower the implement coupled to the lift unit, stop the engine, engage the hand brake and remove the ignition key from the control panel.

- 24) It is strictly prohibited to stand between the tractor and the implement when the engine is running and the cardan shaft is engaging without having first engaged the hand brake and placing a block or stone under the wheels to prevent them from moving.
- 25) Always set the lift control lever to the locked position before coupling or releasing the equipment from the three-point coupling.
- 26) The category of the implement coupling pins should correspond to that of lift coupling.
- 27) Take care when working near the lift links. This is a very dangerous zone.
- 28) It is absolutely forbidden to stand between the tractor and the implement when handling the lift control from outside.
- 29) Fix the side lift links with the relative chains and idlers during the transport phase.
- 30) Set the control lever of the hydraulic lift to the locked position during road transport with the implement raised.
- 31) Only use the cardan shaft recommended by the manufacturer.
- 32) Check the cardan shaft guard frequently and periodically. It must always be in a proper condition.
- 33) Take great care of the cardan shaft guard, both in the transport and working positions.
- 34) The cardan shaft must only be installed or dismantled whilst the engine is off.
- 35) Take great care to ensure that the cardan shaft is correctly assembled and safe, and carefully check the P.T.O. of the rotary tiller and of the tractor.
- 36) Lock the rotation of the protection devices and read the respective cardan shaft Instruction manual thoroughly.
- 37) Before engaging the PTO, ensure that there's nobody in the field of action of the machine and that the selected running rate corresponds to the permissible value.
- 38) Never engage the PTO when the engine is on.
- 39) Always disengage the PTO when the cardan shaft is set at an excessively open angle (never beyond 10 degrees) and when it is not in use.
- 40) Only clean and grease the cardan shaft when the PTO is disengaged, the engine is off, the handbrake engaged and the ignition key is removed.
- 41) Rest the cardan shaft on its stand when not in use.
- 42) Refit the protective cap on the PTO shaft after having dismantled the cardan shaft.
- 43) Over use of the machine can overheat the gear box unit and parts of the hydraulic circuit. Never touch these parts immediately after use as they are very hot and can cause burns.
- 44) Never carry out maintenance or cleaning work unless the PTO has been disengaged, the engine switched off, the hand brake engaged and the tractor locked in position by a block or stone under the wheels.
- 45) Periodically check for all nuts and bolts to be fully tightened. Re-tighten them if necessary.
- 46) Always place adequate supports under the implement when servicing the machine or replacing the hoe blades with the implement raised.
- 47) Before working on the rotary tiller rotor, disengage the PTO, switch off the tractor engine, engage the hand brake and check that the blades are still.
- 48) Only use the recommended oils & grease.
- 49) The spare parts must correspond to the requirements established by the manufacturer. Only use genuine spare parts.
- 50) The safety instructions must always be perfectly visible. They must be kept clean and should be replaced if they become illegible. Replacements are available on request from your local dealer.
- 51) The instruction manual must be kept for as long as the machines last.

3. INSTRUCTIONS FOR OPERATOR

MACHINES SUPPLIED PARTLY

3.1 BROKEN-DOWN

When large volumes are involved, machines can be supplied with parts detached or removed (but always in the same packaging units).

Normally the 3-point frame is shipped separate and will later be fixed to the machine at the customer premises. Execute these installation operations with the utmost care.

Refer to the list of parts in the spare parts catalogue. In particular, apply the screw tightening torques as listed in the chart.

3.2 BEFORE USE

Before starting the machine, check that:

1. The machine is perfectly in order that the lubricants are at the correct levels.
2. Check the rotary tiller is correctly fitted & positioned to obtain the right working depth.
3. Check air breather valve is fitted on gear box and side gear cover.

WARNING

None of the following servicing, adjustment and the preparation operations should be carried out unless the PTO is disengaged, the machine is on the ground, the tractor engine is off and the tractor itself is safely parked & braked.

3.3 HITCHING TO THE TRACTOR

The rotary tiller is coupled to the tractor when the tiller is on the ground. The ground area should be flat.

All the rotary tillers can be attached to any tractor with a class 1 or 2 universal 3-point hitch.

Depending on the precise dimensions of these two of hitches, find the best position for the rotary tiller by moving the front plates along the square tube and insert the pin in the holes corresponding to the correct diameter for the tractor's parallel arms.

DANGER

Mounting of any implement to a tractor is a very dangerous operation and must only be carried out with the utmost care in compliance with the instructions.

The correct tractor/steerage hoe position is established by setting the implement at such a distance from the tractor that the universal coupling remains 5-10 cm from its maximum closing position. Now proceed in the following way:

1. Near the lift bars, setting them in the most suitable place insert the pin into the relative hole and lock in place with the lynch pins.
2. Lock the lift links using the relative chains and couplings parallel to the tractor.
3. Engage the cardan shaft and check that it is perfectly locked on the PTO. Check that the guard is free to turn and fix it with a relative latch. Remove the cardan shaft support and reposition it by fixing it on the relative hook.
4. Connect the upper third point and correctly regulate by means of the adjuster checking that the upper surface of the steerage hoe is parallel to the ground. This is very important since it achieves parallelism between the axis of the steerage hoe and that of the tractor PTO. When the implement operates in these conditions, there will be less stress on the PTO itself while the cardan shaft and implement will be much less subjected to wear.
5. Besides supporting the leveling plate and acting as shock absorber for it during road transport, the spring ram prevents the steerage hoe from overturning when parking. The effect of the leveling plate on the soil can be increased or decreased depending upon the position, established by the split pin in the various holes in the ram tube.

6. When the machine is operating parking stand should be removed. Parking stand should only be installed when the rotary tiller has been lowered to the ground & the machine is parked.

3.4 CARDAN SHAFT

Cardan Shaft adaptation

The cardan shaft, supplied with the machine, is of standard length. Therefore, it might be required to adapt the cardan shaft. In that case, before taking any step consult the Manufacturer for the eventual adaptation.

CAUTION

When the cardan shaft is fully extended, the two tubes must overlap by at least 10-15 cm. When fully inserted, the minimum play must be 4cm.

If the implement is used on another tractor, always check that the guards completely cover the rotating parts of the cardan shaft.

CAUTION

1. Never allow the steerage hoe to operate out of the soil. During work, avoid turning corners while the implement is working. Never work in reverse. Always raise the implement in order to reverse or change direction.
2. During transport, or whenever the implement must be raised, it is advisable to adjust the lift unit of the tractor so that the implement itself is not raised more than about 35 cm from the ground.
3. Do not drive on public highways if the machine is dirtied with soil, grass as it hampers the road traffic.
4. Lower the machine slowly to allow the blades to gradually penetrate the soil.
5. Do not allow it to drop violently on to the ground. To do this would strongly stress all the machine components and could damage them.

3.5 WORKING DEPTH

Rotary tiller working depth is regulated on the basis of the position of the following devices:

1. Side skids

Machine with skids: To adjust working depth on this type of machine you must loosen the adjustment pin and raise or lower the skid to the desired extent. Then reposition the pin. Both skids should be subjected to this operation, which will vary according to the type of soil.

3.6 CHAIN TENSIONER

A special mechanical chain tensioner regulates the tension of the drive chain. This device works against coiled spring tensioner.

3.7 HOE BLADES

Check the degree of wear and condition of the hoe blades daily. If the blades accidentally bend (or break) during work, they must be immediately replaced.

Remember to mount the new hoe blade in exactly the same position as the old one. If several hoe blades must be replaced, it is advisable to remove and assemble one hoe blade at a time in order to prevent positioning errors.

The steerage hoes are normally equipped with 4 blades per flange. When the soil is dry to clog it is, however, possible to mount 6 hoe blades per flange. The heads of the bolts fixing the hoe blades in place must be on the side of the hoe blades themselves, while the nut with relative washer must be on the flange side. Apply the tightening torques as listed in the chart. If the hoe blades must be changed, remember to set the new blades in the same positions as the dismantled ones.

3.8 IN WORKING

Start working with the PTO at running rate, gradually lowering the steerage hoe into the soil. Never excessively press down on the accelerator pedal when the PTO is engaged. This could be very harmful for both the steerage hoe and the tractor itself. When choosing how much to break up the soil that is to be rotary hoed the following points must be considered:

1. The type of soil (mixed, sandy, clayed etc.)
2. How deep to hoe
3. The forward moving speed of the rotary tiller/tractor.

The soil is best broken up and rotary hoed with a slow forward moving speed of the tractor, with the leveling blade lowered and a blade carrying rotor rotation speed of about 180-210 rpm. The plank helps to produce a well-leveled and smooth surface after hoeing.

If the plank is raised the sods/clog are no longer broken up and there will not be a smooth, level finish.

3.9 HOW IT WORKS

Position the Plank according to how finely broken soil should be. Position the depth of the two skids that are on the sides of the rotary tiller. Start to move the tractor forward gradually lowering the rotary tiller.

After a short distance check whether the soil is being hoed to the depth required, broken up finely enough and levelled enough.

CAUTIONS

In order to prevent breakages or damage, the speed of the tractor must never exceed 2-5 km/hr while the implement is working.

3.10 TROUBLESHOOTING HINTS FOR THE TRACTOR OPERATOR

INSUFFICIENT DEPTH

1. Check the positioning of the two depth skids.
2. Move forward slower as the power of the tractor may be insufficient.
3. If the soil is too hard a second or third hoeing may be required.
4. If the hoe blades are rotating on top of the soil instead of cutting into it proceed more slowly.

THE SOIL IS TOO FINELY BROKEN UP

1. Raise the leveling blade.
2. Increase the forward moving speed of the tractor.

THE SOIL IS NOT BROKEN UP FINELY ENOUGH

1. Lower the leveling blade.
2. Reduce the tractor speed.
3. Don't work soil that is too wet.
4. In the rotary hoes fitted with a leveling bar, raise or lower this so as to keep the sods closer to the hoe blades.

CLOGGING UP THE ROTOR

1. The soil is too wet for hoeing.
2. Raise the leveling blade.
3. Reduce the tractor speed.
4. Reduce the number of the hoe blades per flange from six to four.
5. Avoid hoeing where there is long grass.

THE ROTARY HOE BOUNCES OVER THE SOIL OR VIBRATES

1. There are foreign bodies caught between the hoe blades.
2. The hoe blades have been incorrectly assembled thereby not forming. The helix shape or with the blunt edge placed to cut into the soil first instead of the cutting edge.
3. Worn or broken hoe blades.
4. The rotor is deformed because of blows to the central part caused by foreign bodies present during hoeing.

OTHER PROBLEMS

The rotary hoe does not hoe to the same depth over the whole width. E.g. if it hoes too deeply on the right side shorten the right arm of the lift bars and regulate the position of the right hand skid.

WORKING ON A HILL/SLOPE

Where possible always try to 'work up' the slope. If this is not possible avoid hoeing along the contours of the hill and hoe up and down the slope to avoid a terracing effect.

PRACTICAL NOTES

The hoed soil should be on the right of the driver the best system is to hoe the alternate strips.

3.11 PARKING

WARNING

Comply with the following instruction in order to ensure that the implement remains stable when released from the tractor.

1. Besides supporting the leveling plate and acting as a shock absorber for it during road transport, the spring ram prevents the steerage hoe from over turning when parking.
2. Hold the cardan shaft with a suitable support.

4. MAINTENANCE

The various servicing operation are listed in the following paragraphs.

Lower running costs and longer machine life depend on constant and methodical compliance with these operations.

CAUTION

The given frequencies are indicative and refer to normal conditions of use. They may therefore be subjected to variations in relation to the type of service, in more or less dusty environment, seasonal factors, etc.

In the case of heavy-duty condition, the maintenance operation should obviously be more frequent.

Before injecting grease into the lubricators, the greasing points must be thoroughly cleaned to prevent mud, dust or foreign bodies from mixing with the lubricants, thus reducing or even annulling its lubricating effect.

When topping up or changing the lubricant, always ensure that the oil is of the same type as that used previously.

WARNING

Always keep oil and greases well away from children's reach. Always thoroughly read the warnings and precautions indicated on the containers.

Avoid contact with the skin.

Always thoroughly and fully wash after use. The utilized oils should be treated in compliance with the current anti-pollution laws.

4.1 EVERY 8 WORK HOURS

Grease the cardan shaft cross journals.

Check that the bolts fixing the hoe blades are well tightened.

4.2 EVERY 50 WORK HOURS

Check the level of the oil in the gearbox or in the reduction unit and top up to the level mark on the rod as necessary.

Transmission lateral part chain: check the level of the oil in the side casing of the transmission unit.

Add oil through the fill plug if necessary. It should flow from the level plug.

4.3 EVERY 200 WORK HOURS

Change the oil in the gearbox or in the reduction unit and transmission casing by completely draining of the old oil through the drain plug, under the reduction unit and through the transmission drain plug.

4.4 STORAGE

It is advisable to proceed in the following way at the end of the season or if the machine is to remain inactive for a long period of time:

1. Wash the implement, particularly removing any fertilizer and/or chemical products, and then thoroughly dry it.
2. Carefully check for any damaged or worn parts and replace these if necessary.

3. Fully check screws or bolts, particularly those fixing the hoe blades.
4. Thoroughly lubricate the implement and lastly protect it with a plastic sheet. Store it in a dry place.

Careful compliance with these instructions will be all to the advantage of the user who will be sure to use an implement in perfect conditions when work begins again. Remember that the manufacturer is always at your disposal for any assistance or spare parts as may be required.

4.5 LUBRICANTS

It is advisable to use SAE 140 EP Grade OIL or equivalent for the gear box unit and side transmission.

It is advisable to use high quality grease for all greasing points.

5. SERVICING TIPS

1. **Problem**--P.T.O shaft is rotating with constant speed but not the gear box.

Cause of problem -- Safety bolt might be broken

Solution – Replace the safety bolt.

- a) Remove the P.T.O shaft from the R.T side.
- b) Dislodge the safety bolt and replace it.

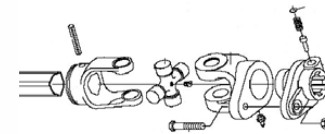

2. **Problem**—P.T.O shaft is making noise/ vibration.

Cause of problem – P.T.O cross is broken.

Solution – Change the P.T.O cross.

- a) Take the P.T.O shaft and check the cross of both side by rotating it.
- b) Remove the lock of the cross which is broken.
- c) Take out the cross by using hammer gently.
- d) Insert the new one properly then lock it.
- e) Rotate the yoke, it should rotate properly.
- f) Make the greasing properly.

3. **Problem**—Yoke is not fitting on the pinion shaft.

Cause of problem – Yoke pin is broken.

Solution – Replace the yoke pin.

- a) Clear the head of the pin push it with with hammer and remove it
- B) Replace it with new one.
- c) Take care of proper cleaning and greasing.

4. **Problem**—Rotary tiller is not taking proper depth.

Cause of problem— Side depth skids need to be adjusted.

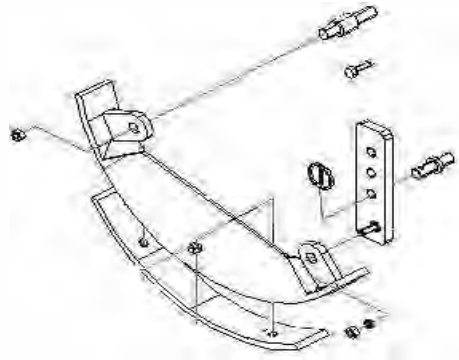

Solution –

- a) Lose the side skid bolt .
- b) Shift the hole to the upper side.

2. **Problem—**R.T. is taking on one side more depth.

Cause of problem –linkage is not proper

Solution –Linkage adjustment should be proper.

- a. Tractor linkage should be tight.
- b. There should not be any play more then 1.5”(38MM).
- c. At the time of attaching the rotary tiller the R.T should be in proper leveled position.
- d. Both side skids should be in same bolt position.

3. **Problem—**Gear box is noisy.

Cause of problem –Play in bearing or teeth broken.

Solution –Replace the bearing or bevel gear.

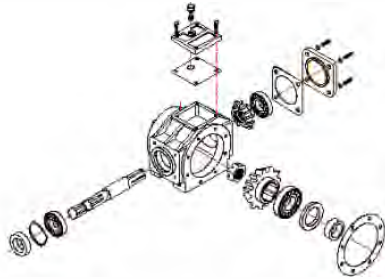

- a) Open the top cover to see the wear of the teeth
- b) If the teeth of the gear is broken the bevel set needs to be replaced.
- c) Pull out the gear box and open the big flange.
- d) Then remove the back plate
- e) Pull out the pinion shaft using hammer or press machine.
- f) Replace the bearing, gear and seals.
- g) Make the fitment in the same way using new gasket.
- h) The gear should rotate freely.
- i) Assemble it back the breather valve should be clean and oiling should be checked.

2. **Problem—**Gear shafts are rotating but not the chain/rotor

Cause of problem –Transmission shaft / chain/ RD shaft is broken

Solution –Open the chain cover and replace the part which is broken.

- a. First remove the lock & loose the check nut.
- b. Pull out the sprocket assembly with chain.
- c. If the transmission shaft is broken, follow the same process as above and replace the shaft then assemble the gear box with rotary tiller.
- d. If chain is broken then replace the chain and assemble the sprockets together with chain & then tighten the check nuts.

For RD shaft the process will be different

- e. First open the flange bolt of the rotor on both side (RD shaft and Dead shaft) and remove the rotor.
- f. Loosen the check nut of RD shaft and hammer it till it gets out from the RD shaft hub & then replace the RD shaft and tight the check nut. Take care of the seal as it should not be harmed with this replacement.

The same process be followed for dead shaft replacement.

3. **Problem—**Oil leakage from the RD shaft hub or dead hub.

Cause of problem –Seal is wearing out needs to be replaced it.

Solution – Open the hub assembly as before

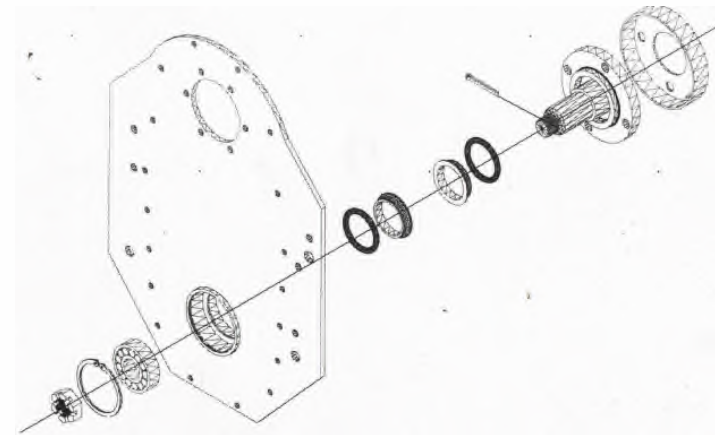

- a. Take out the hub from the plate by loosening the bolts
- b. Remove the lock and pull out the shaft.
- c. Pull out the seal from both shaft and hub then replace it with new one
- d. Inspect the position of bearing and hub if it is ok. Clean it and assemble as before.
- e. Proper greasing is very necessary in assembly processes.

Problem - While Shifting gears , two speeds (Neutral to high or Neutral to low) easily shift
When rotary tiller is in non-working condition, but hard to shift all three
(Neutral-high-low) in same condition.

Cause of Problem - Combination gear Design limitation.

Solution - Slightly rotate PTO for shift all three position (High-Neutral-Low) smoothly.

ROTARY TILLER SIDE PLATE AND ROTOR ASSEMBLY			
SR. NO.	DESCRIPTION	ITEM CODE	QTY.
1	HEX HEAD BOLT 6X16X1MM (P)	10260359	6
2	DEAD HUB CAP ROUND	10180001	1
3	GASKET DEAD HUB CAP	10040026	1
4	HEX. HEAD BOLT M10X35X1.5	10260353	6
5	SIDE PLATE BIG LHS (18X33X28)	78910002	1
	SIDE PLATE BIG LHS (19X33X25)	78910003	
6	SPLIT PIN 1/8X2.5 INCH	10020097	1
7	CASTLE NUT M30X1.5	10280093	1
8	CIRCLIP 95MM	10390014	1
9	BEARING 6308	10050051	1
10	DEAD HUB (OIL SEAL TYPE) (ROUND) NEW	10090021	1
11	PLAIN NUT 10X1.5MM	10280036	12
12	OIL SEAL 55X75X15	10010023	1
13	DEAD SHAFT BUSH	10070042	1
14	DEAD AXLE SHAFT NEW ROUND (OIL SEAL TYPE)	10110002	1
15	ROTOR COVER	10150003	2
16	SPRING WASHER 16MM	10270005	8
17	HEX HEAD BOLT M16X35X1.5MM	10260369	8
18	ROTOR ASSEMBLY (1.75 MTS.)	73210001	1
	ROTOR ASSEMBLY (2.00 MTS.)	73220001	
	ROTOR ASSEMBLY (2.25 MTS.)	73230001	
19	HOE LHS (L TYPE)	10060016	3 PER FLANGE
	HOE LHS (C TYPE)	10060035	
20	HOE RHS (L TYPE)	10060017	3 PER FLANGE
	HOE RHS (C TYPE)	10060034	
21	HEX HEAD BOLT 14X40X1.5MM	10260357	12 PER FLANGE
22	SPRING WASHER 14MM	10270004	12 PER FLANGE
23	NYLOCK NUT M14X2	10280090	12 PER FLANGE
24	RD SHAFT BUSH	10070002	1
25	RD SHAFT (OIL SEAL TYPE) 10 SPLINES	10290017	1
26	OIL SEAL 65X85X16(DOUBLE SPRING TYPE)	10010136	1
27	RD HUB (OIL SEAL TYPE) (ROUND)	10090010	1
28	BEARING 6310	10050053	1
29	CIRCLIP 118MM	10390013	1
30	GASKET RD HUB	10040025	1
31	SIDE PLATE RHS (GEAR TYPE) (18X33X28)	73590002	1
	SIDE PLATE RHS (GEAR TYPE) (19X33X25)	70040004	

SIDE PLATE & ROTOR ASSEMBLY

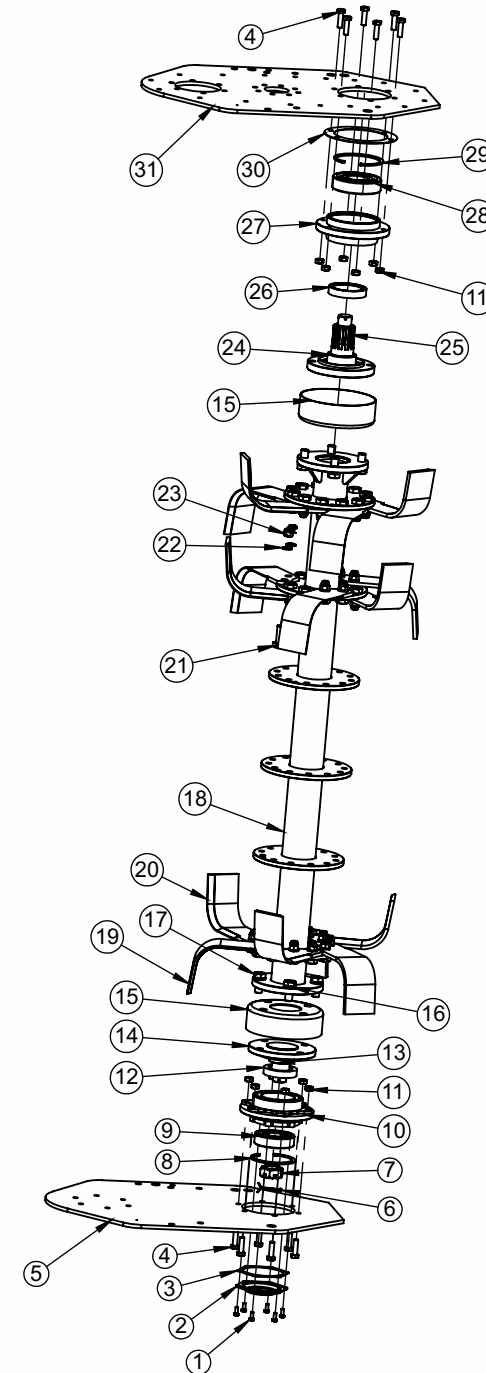

HYDRAULIC SIDE SHIFT ROTARY TILLER COMPLETE ASSEMBLY			
SR. NO.	DESCRIPTION	ITEM CODE	QTY.
1	HEX HEAD BOLT M8X1.25X40	10260373	2
2	HEX HEAD BOLT M8X1.25X25	10260360	16
3	GEAR COVER	10150006	1
4	BREATHER NUT M22X1.5	10280010	2
5	BREATHER VALVE	10190001	2
6	SPLIT PIN 1/8 2.5"	10020097	3
7	CASTLE NUT M30X1.5P	10280093	2
8	CASTLE NUT M36X2P	10280071	1
9	BEARING 32209	10050013	2
10	SPUR GEAR 18T-8S	10250023	1
	SPUR GEAR 19T-8S	10250029	
11	SPUR GEAR Z33	10250015	1
12	SPUR GEAR 28T-10S	10250019	1
	SPUR GEAR 25T-10S	10250030	
13	CIRCLIP B85	10390032	1
14	SPACER 45X4	10300096	1
15	RD SHAFT	10290017	1
16	IDLER PIN	10020004	1
17	HEX HEAD BOLT M12X35X1.75P	10260362	8
18	HEX HEAD BOLT M10X35X1.50P	10260353	32
19	SPRING WASHER 12MM	10270003	35
20	NYLOCK NUT M12X1.75P	10280025	35
21	GUIDE MOUNTING FLANGE	70010200	2
22	HEX HEAD BOLT M12X40X1.75P	10260355	8
23	HYDRAULIC CYLINDER	10450023	1
24	CSK BOLT M12X50X1.75P	10260050	1
25	OIL LEVEL INDICATOR	10300117	1
26	HEX HEAD BOLT M12X50X1.75P	10260363	16
27	3-POINT LINKAGE ASSEMBLY	74750012	1
28	DEPTH WHEEL ASSEMBLY	74750015	2
29	HEX HEAD BOLT M16X75X2.0P	10260370	4
30	SPRING WASHER 16MM	10270005	4
31	NYLOCK NUT M16X2P	10280005	4
32	TILLER PIN 28X145 WITH HANDLE	10020047	2
33	LINCH PIN 10MM	10020022	2
34	RT DEPTH SKID ASSY RHS	71570030	1
35	RT DEPTH SKID ASSY LHS	73420008	1
36	HEX HEAD BOLT M18X65X2.5P	10260376	4
37	SPRING WASHER 18	10270006	4
38	NYLOCK NUT M18X2.5P	10280020	4
39	HYDRAULIC CYLINDER GUIDE	10450038	1
40	HEX HEAD BOLT M12X60X1.75P	10260356	1
41	PIN 25X125	10020047	1
42	TOP LINK ASSEMBLY	73570044	1

HYDRAULIC SIDE SHIFT ROTARY TILLER COMPLETE ASSEMBLY

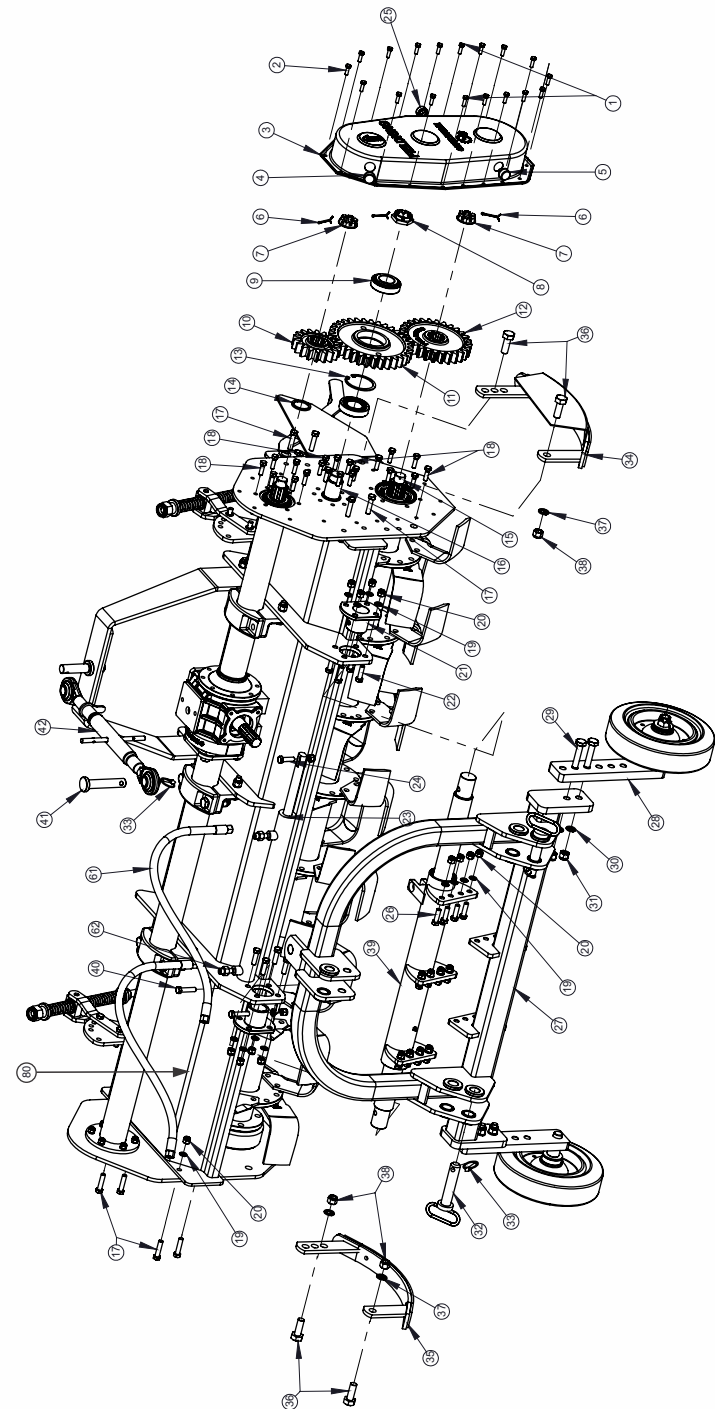

HYDRAULIC SIDE SHIFT ROTARY TILLER COMPLETE ASSEMBLY			
SR. NO	DESCRIPTION	ITEM CODE	QTY
43	TOP LINK MOUNTING PIN 28X170 (THREADED)	10020327	1
44	TOP LINK MOUNTING FLAT ASSY	70010175	1
45	GEAR BOX ASSEMBLY 1.00 MTR (1.75 MTR MODEL)	73650002	1
	GEAR BOX ASSEMBLY 1.25 MTR (2.00 MTR MODEL)	73660002	
	GEAR BOX ASSEMBLY 1.50 MTR (2.25 MTR MODEL)	73670002	
46	PLANK ROD SUPPORT PLATE	70020050	2
47	HEX HEAD BOLT M10X30X1.50P	10260396	2
48	CSK BOLT M10X35X1.5P	10260027	4
49	SPRING WASHER 10MM	10270002	6
50	NYLOCK NUT M10X1.5P	10280002	6
51	PLANK ROD 1.75 MTR	10160033	2
	PLANK ROD 2.00 MTR	10160032	
	PLANK ROD 2.25 MTR	10160037	
52	SHOCKER-PLANK ATTACHMENT INNER SUPPORT	70020026	2
53	PLANK ASSEMBLY 1.75 MTR	73090001	1
	PLANK ASSEMBLY 2.00 MTR	73100001	
	PLANK ASSEMBLY 2.25 MTR	73110001	
54	HEX HEAD BOLT M12X90X1.75P	10260364	2
55	SHOCKER-PLANK ATTACHMENT (U-CLAMP)	10220003	2
56	PLAIN WASHER 14MM	10270030	6
57	FRAME-SHOCKER HOLDING CLAMP	70020012	4
58	GEARBOX SIDE MOUNTING PIPE ASSY 1.75 MTR	74790030	1
	GEARBOX SIDE MOUNTING PIPE ASSY 2.00 MTR	74790036	
	GEARBOX SIDE MOUNTING PIPE ASSY 2.25 MTR	74790037	
59	HEX HEX BOLT M14X35X2P	10260372	4
60	HEX HEAD BOLT 16X65X2P	10260378	6
61	HYD HOSE PIPE 3/8(SAE100R2AT) 55 INCH	10440014	2
62	HYDRAULIC CYLINDER ADOPTER 1/4X3/8	20052338	2
63	TRANSMISSION PIPE CLAMP UPPER (HEAVY DUTY)	10220022	3
64	TRANSMISSION PIPE CLAMP LOWER (HEAVY DUTY)	10220003	3
65	HEX HEX BOLT M14X50X2P	10260386	4
66	SPRING WASHER 14MM	10270004	10
67	NYLOCK NUT M14X2P	10280090	10
68	HEX HEX BOLT M14X60X2P	10260399	6
69	SHOCKER ASSEMBLY	73180001	2
70	SHOCKER ROD	10160006	1
71	RIVIT 5X35	20050422	1
72	SHOCKER SPRING CUP LOWER	10180018	1
73	SHOCKER SPRING BIG	10210002	1
74	SQUARE BUSH	10070003	1
75	SHOCKER SRING SMALL	10210003	1
76	SHOCKER SPRING CUP UPPER	10180002	1
77	NYLOCK NUT M18X1.5P	10280006	1
78	RT PLANK GUARD LHS	10150029	1
79	RT PLANK GUARD RHS	10150031	1
80	FRAME ASSEMBLY 1.75 MTR (HYD SIDE SHIFT RT)	70010209	1
	FRAME ASSEMBLY 2.00 MTR (HYD SIDE SHIFT RT)	70010191	
	FRAME ASSEMBLY 2.25 MTR (HYD SIDE SHIFT RT)	70010208	

HYDRAULIC SIDE SHIFT ROTARY TILLER COMPLETE ASSEMBLY

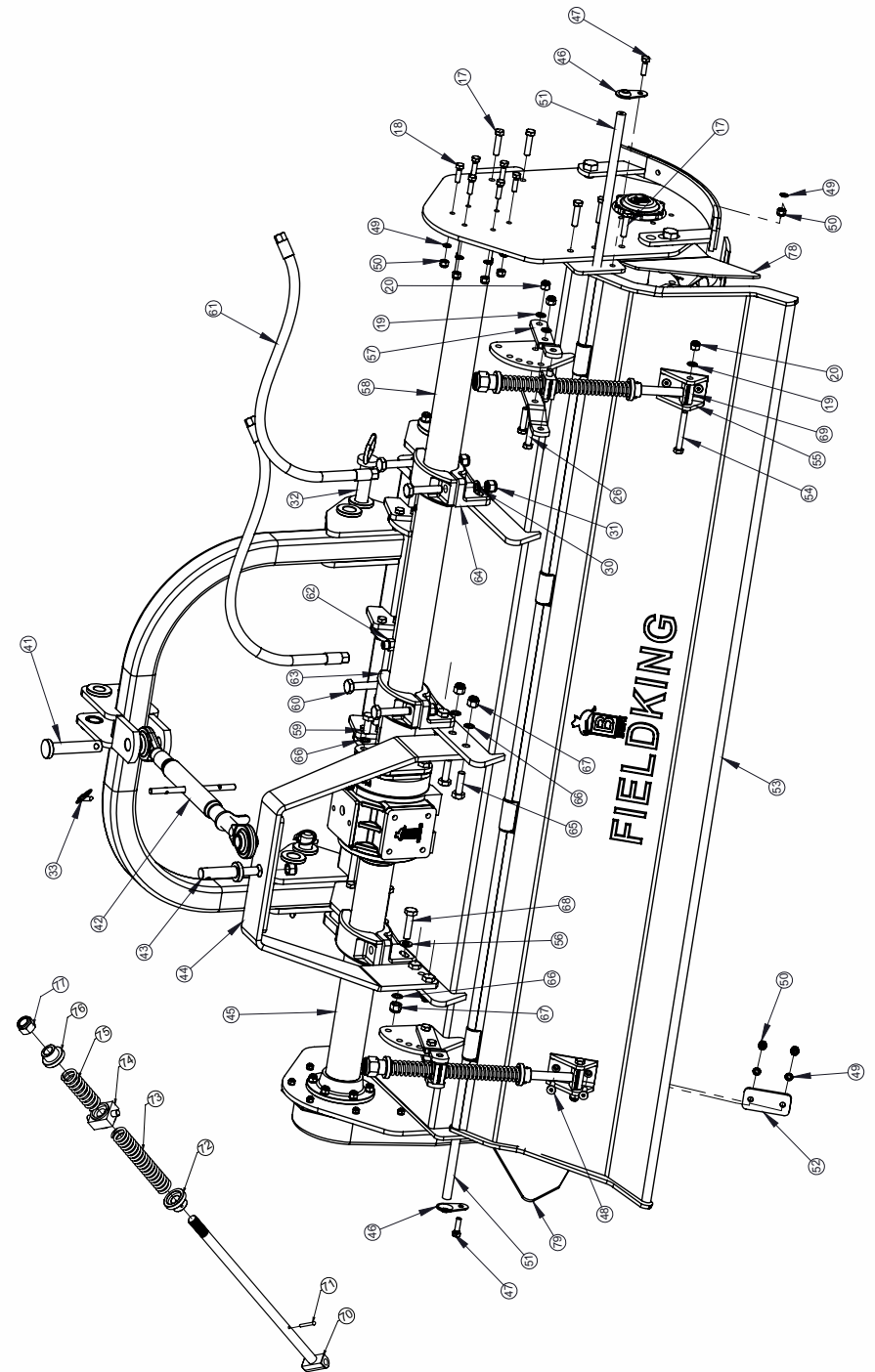

SINGLESPEED(11X20) GEARBOX ASSEMBLY			
SR. NO	DESCRIPTION	ITEM CODE	QTY
1	GEAR BOX HOUSING (SINGLE SPEED)11X20	10080001	1
2	PINION SHAFT (SINGLE SPEED)	10290010	1
3	BEARING 30207	10050100	1
4	CIRCLIP 72MM (INTERNAL)	10390022	1
5	OIL SEAL 35X72X10	10010001	1
6	PINION GEAR 11TX6 SPLINES	10250018	1
7	BEARING 30210	10050097	1
8	CIRCLIP 95MM	10390014	1
9	GEAR BOX REAR BEARING PLATE (SINGLE SPEED)	73620002	1
10	SPRING WASHER 10MM	10270002	14
11	HEX HEAD BOLT M10X30X1.5MM	10260396	12
12	GASKET TOP PLATE GEAR BOX 109X109X1.5MM (11X20)	10040033	1
13	GEAR BOX TOP PLATE	73620003	1
14	DIP STICK	10300001	1
15	BREATHER NUT 22X1.5MM	10280010	1
16	BREATHER VALVE	10190001	1
17	HEX HEAD BOLT M10X25X1.5MM	10260361	2
18	BEARING 32209	10050013	1
19	TRANSMISSION PIPE ASSEMBLY-1.00 MTS.	73820001	1
	TRANSMISSION PIPE ASSEMBLY-1.25 MTS.	71590004	
	TRANSMISSION PIPE ASSEMBLY-1.50 MTR	73830001	
20	GASKET BIG FLANGE (8 HOLE) SS	10040009	1
21	TRANSMISSION SHAFT-1408S-S100	10290026	1
	TRANSMISSION SHAFT 1408S-S125	10290006	
	TRANSMISSION SHAFT 1408S-S150	10290003	
22	TRANSMISSION SHAFT BUSH	10070038	1
23	OIL SEAL 55X80X10	10010002	1
24	BEARING 32211	10050009	1
25	BEVEL GEAR 20TX14 SPLINES	10250007	1
26	CASTLE NUT M30X1.5M	10280093	1
27	SPLIT PIN 1/8X2.5 INCH	10020097	1

REGULAR SINGLE SPEED GEAR BOX ASSEMBLY

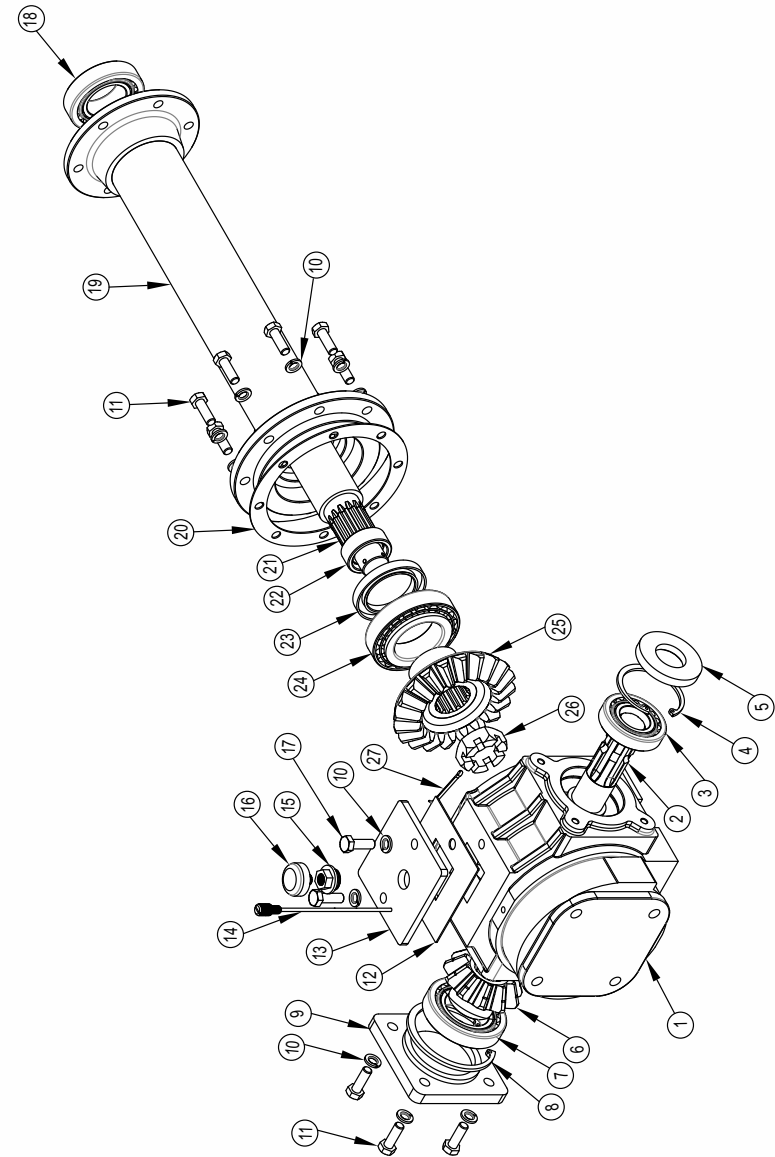

SIDE DISC ASSEMBLY (78960001)			
SR. NO.	DESCRIPTION	ITEM CODE	QTY.
1	HEX BOLT M8X20X1.25	10260188	6
2	SIDE DISC HUB FRONT COVER	10150007	2
3	CASTLE NUT M30X1.5	10280012	1
4	BEARING 32307	10050008	2
5	SIDE DISC HUB	10090001	1
6	OIL SEAL 40X80X10	10010005	1
7	SIDE DISC HUB BACK COVER	10150008	1
8	NYLOCK NUT M10X1.5MM	10280002	3
9	SPRING WASHER 10MM	10270002	3
10	SIDE DISC HUB AXLE (COMPLETE SET)	10110001	1
11	PLAIN DISC 14 INCH (SIDE DISC RT)	10240001	1
12	CSK BOLT M10X30X1.5MM	10260051	3
13	SIDE DISC MOUNTING PIPE ASSEMBLY	73460001	1
14	HEX HEAD BOLT 12X20X1.75MM (10.9 GRADE)	10260057	4
15	PIN 19X90MM	10020026	1
16	LINCH PIN 10MM	10020022	1
17	SIDE DISC ATTACHMENT FRAME ASSEMBLY	73450001	4
18	U-CLAMP 100X62X12	10220028	2
19	SPRING WASHER 12MM	10270003	4
20	NYLOCK NUT M12X1.5(P)	10280003	4

SIDE DISC ATTACHMENT ASSEMBLY

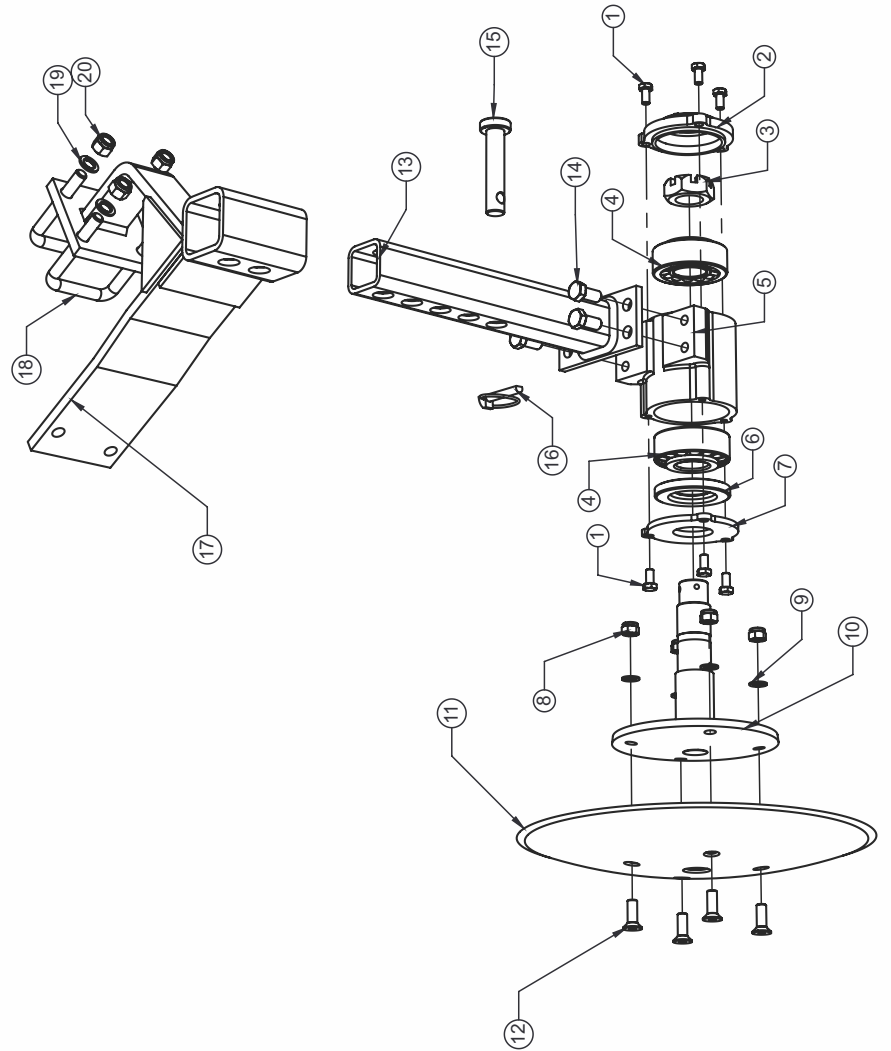

Rotary Tiller PTO Shaft

Sr No.	Description	Part Code			
		540 RPM		1000 RPM	
		CUT	FULL	CUT	FULL
1	PTO PUSH PIN YOKE WITH PIN - 38.05.10B (12X10)	10310059	10310060	10310083	10310084
2	PTO CROSS JOURNAL SET-38.01	10310073		10310065	
3	PTO OUTER TUBE YOKE -38			10310097	
4	DOWEL PIN 10X80 MM			10020118	
5	INNER TUBE	10310039			
6	OUTER TUBE	10310040			
7	PTO INNER TUBE YOKE -38			10310096	
8	PTO COMPLETE SHEAR BOLT ASSEMBLY (6SPLINE)- 38SBT (12X10)	10310011		10310071	
9	GUARD RETAINING COLLAR FOR OUTER TUBE	10310012			
10	GUARD RETAINING COLLAR FOR INNER TUBE	10310013			
11	SAFETY CHAINS	10310014	10310047	10310014	10310047
12	COMPLETE GUARD ASSEMBLY			10310077	
13	PTO PUSH PIN SET-14X69 (Small)			10310078	
14	PTO PUSH PIN SET-14X91 (Big)			10310030	
15	YOKE FOR B02			10310017	
16	BALL 5/16"			10310042	
17	HUB B02				
18	HEX HEAD BOLT M10X65X1.5MM SAFETY BOLT	10260046			
19	NYLOCK NUT M10X1.5MM	10280002			
20	GREASE FITTING	10310019			
21	U-JOINT FOR OUTER TUBE	10310020		10310056	
22	U-JOINT FOR INNER TUBE		10310021		
23	HALF FEMALE GUARD ASSY.	10310048	10310051	10310048	10310051
24	HALF MALE GUARD ASSY.	10310049	10310050	10310049	10310050

PTO ASSEMBLY-SHEAR BOLT TYPE

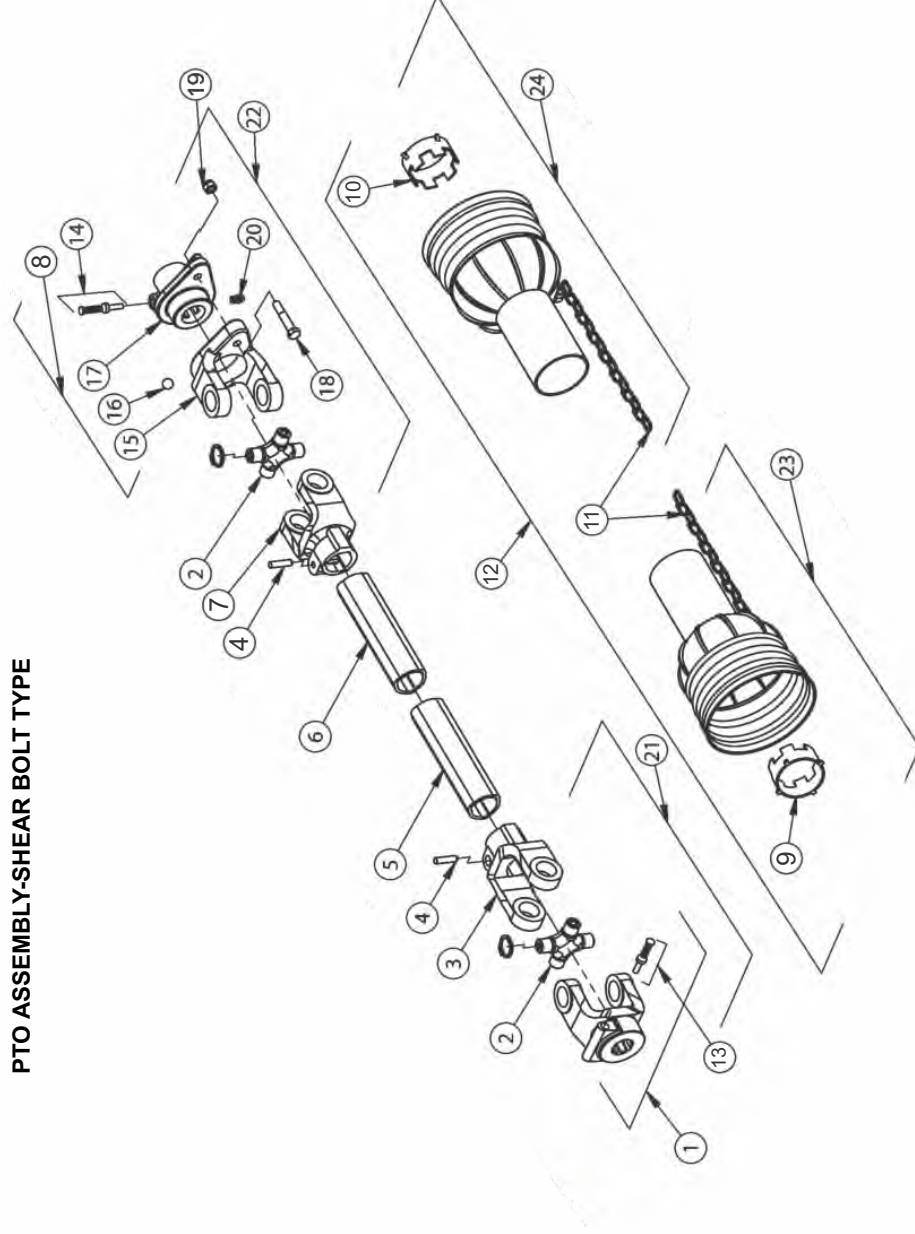

PTO SHAFT ASSEMBLY - SLIP CLUTCH TYPE (10310062)
(Optional)

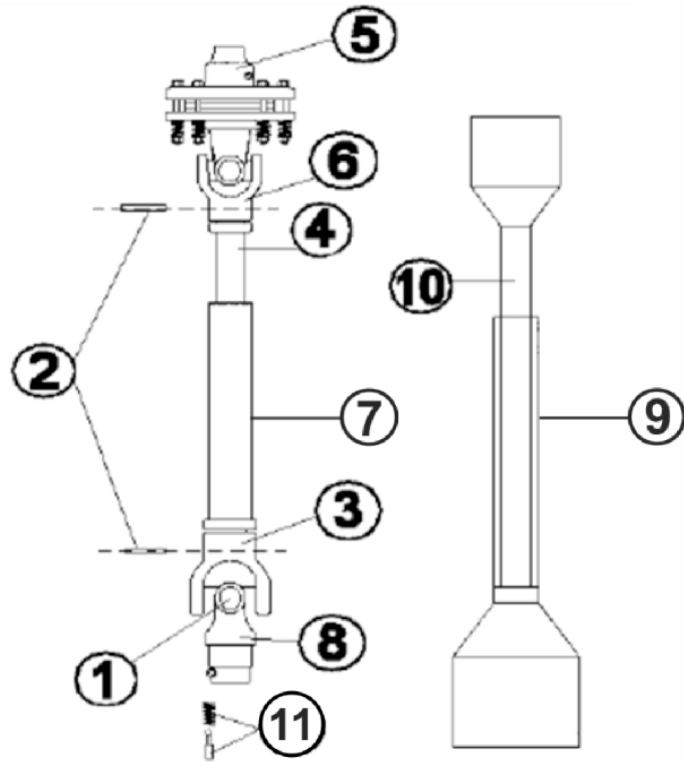

S.No.	DESCRIPTION	ITEM CODE	QTY
1	CROSS JOURNAL SET	10310003	2
2	SPRING DOWEL PIN SET (SLIP CLUTCH PTO)	10210031	2
3	OUTER TUBE YOKE	10310004	1
4	INNER TUBE (CUT PTO)	10310039	1
5	SLIP CLUTCH ASSEMBLY	10310127	1
6	INNER TUBE YOKE	10310009	1
7	OUTER TUBE (CUT PTO)	10310040	1
8	PUSH PIN YOKE WITH PIN (6 SPLINES)	10310002	1
9	HALF FEMALE GUARD ASSY. (CUT)	10310048	1
10	HALF MALE GUARD ASSY. (CUT)	10310049	1
11	PUSH PIN SET	10310015	1

SLIP CLUTCH ASSEMBLY (10310127)

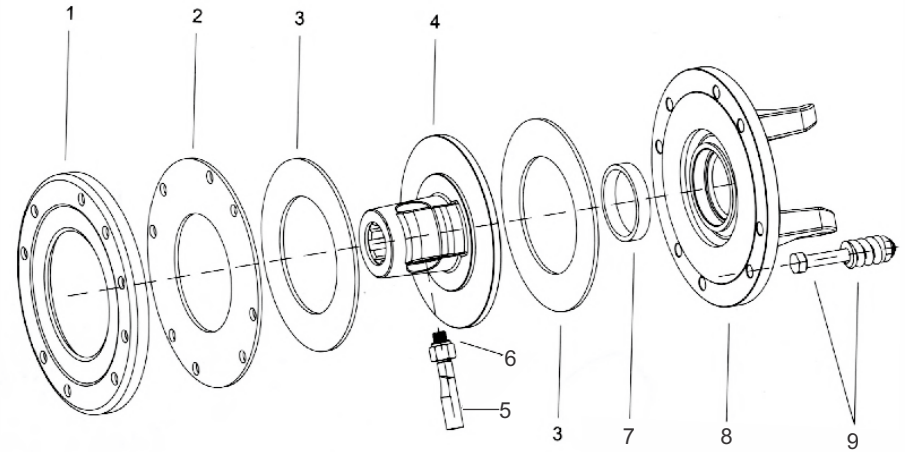

SLIP CLUTCH ASSEMBLY(10310127)			
SR.NO.	PART NAME	ITEM CODE	QTY
1	PRESSURE PLATE	10310128	1
2	INTERNAL DISC	10310129	1
3	FRICITION LINING	10310130	2
4	HUB	10310131	1
5	HUB BOLT M12X70X1.75P	10260407	2
6	NYLOCK NUT M12X1.75P	10280025	2
7	BUSHING	10310132	1
8	FLANGED SPLINE	10310133	1
9	COMPLETE BOLT & SPRING	10310134	8

COMPATIBILITY CHART OF TRACTORS WITH ROTARY TILLER

Name	Model	E.H.P.	ERPm	PTO RPM	Compatible ERPm	Gear Used for Rotavator	Rotavator sizes selection according to soil condition				Side Gear Selection	Fielding Single Speed Rotor RPM					Fielding Multi Speed Rotor with 18-33-28					Fielding Multi Speed Rotor with 19-33-25													
							Hard	Medium	Light	18-33-28					19-33-25					16-20					17-19					14-22					
										190		200	225	225	225	225	190	200	225	225	225	225	16-20	17-19	14-22	22-14	16-20	17-19	14-22	22-14	16-20	17-19	14-22	22-14	
MAHINDRA	265 DI	31 HP	1900	540	1800-1900	L-2	125	150	150	150	1833x28	190	NA	NA	144	226	162	202	213	525	171	267	191	239	251	621									
	295 DI	39 HP	1900	540	1800-1900	L-2	150	175	175	1833x28	190	NA	NA	144	226	162	202	213	525	171	267	191	239	251	621										
	445 DI	42 HP	2187	540	1800-1900	L-2	150	175	175	1833x28	190	NA	NA	144	226	162	202	213	525	171	267	191	239	251	621										
	575 DI	45 HP	1900	540	1800-1900	L-2	150	175	200	1833x28	190	NA	NA	144	226	162	202	213	525	171	267	191	239	251	621										
	585 DI	50 HP	1980	540	1800-1900	L-2	175	200	200	1833x28	190	NA	NA	144	226	162	202	213	525	171	267	191	239	251	621										
	595 DI	52 HP	2059	540	1800-1900	L-2	175	200	200	1933x25	NA	226	NA	NA	NA	NA	NA	NA	NA	NA	NA	171	267	191	239	251	621								
JOHN DEERE	565 DI	54 HP	2187	540	1800-1900	L-2	175	200	200	1933x25	NA	226	NA	NA	NA	NA	NA	NA	NA	NA	171	267	191	239	251	621									
	605 DI	57 HP	2187	540	1800-1900	L-2	200	225	225	1933x25	NA	226	NA	NA	NA	NA	NA	NA	NA	NA	NA	171	267	191	239	251	621								
	5036 C	35 HP	1575	540	1800-1900	A-1 & A-2	150	150	175	1933x25	NA	226	NA	NA	NA	NA	NA	NA	NA	NA	NA	171	267	191	239	251	621								
	5038 C	38 HP	2200	540	1800-1900	A-1 & A-2	150	150	175	1933x25	NA	226	NA	NA	NA	NA	NA	NA	NA	NA	NA	171	267	191	239	251	621								
	5103	40 HP	2200	540	1800-1900	A-1 & A-2	150	175	175	1933x25	NA	226	NA	NA	NA	NA	NA	NA	NA	NA	NA	171	267	191	239	251	621								
	5041 C	41 HP	1575	540	1800-1900	A-1 & A-2	150	175	175	1933x25	NA	226	NA	NA	NA	NA	NA	NA	NA	NA	NA	171	267	191	239	251	621								
TAKE	5103 C	42 HP	2200	540	1800-1900	A-1 & A-2	150	175	175	1933x25	NA	226	NA	NA	NA	NA	NA	NA	NA	NA	NA	171	267	191	239	251	621								
	5104	45 HP	2200	540	1800-1900	A-1 & A-2	150	175	200	1933x25	NA	226	NA	NA	NA	NA	NA	NA	NA	NA	NA	171	267	191	239	251	621								
	5204	50 HP	2200	540	1800-1900	A-1 & A-2	175	200	200	1933x25	NA	226	NA	NA	NA	NA	NA	NA	NA	NA	NA	171	267	191	239	251	621								
	5310	55 HP	2376	540	1800-1900	A-1 & A-2	200	225	225	1933x25	NA	226	NA	NA	NA	NA	NA	NA	NA	NA	NA	171	267	191	239	251	621								
	5060 E	60 HP	2376	540	1800-1900	A-1 & A-2	200	225	225	1933x25	NA	226	NA	NA	NA	NA	NA	NA	NA	NA	NA	171	267	191	239	251	621								
	5410	65 HP	2376	540	1800-1900	A-1 & A-2	200	225	225	1933x25	NA	226	NA	NA	NA	NA	NA	NA	NA	NA	NA	171	267	191	239	251	621								
FARM TRAC	5610 MFWD	75 HP	2376	540	1800-1900	A-1 & A-2	225	225	225	1933x25	NA	226	NA	NA	NA	NA	NA	NA	NA	NA	NA	171	267	191	239	251	621								
	MF 1030 DI	30 HP	1500	540	1800-1900	L-2	125	150	150	1833x28	190	226	144	226	162	202	213	525	171	267	191	239	251	621											
	MF 1035 DI	39 HP	1500	540	1800-1900	L-2	150	150	175	1833x28	190	226	144	226	162	202	213	525	171	267	191	239	251	621											
	MF 241 DI	42 HP	1500	540	1800-1900	L-2	150	175	175	1833x28	190	226	144	226	162	202	213	525	171	267	191	239	251	621											
	MF 245 DI	47 HP	1789	540	1800-1900	L-2	150	175	200	1933x25	NA	226	NA	NA	NA	NA	NA	NA	NA	NA	NA	171	267	191	239	251	621								
	MD 7250 DI	47 HP	1735	540	1800-1900	L-2	150	175	200	1833x28	190	226	144	226	162	202	213	525	171	267	191	239	251	621											
H.M.T.	MD 5245 DI	50 HP	1790	540	1800-1900	L-2	175	200	200	1833x28	190	226	144	226	162	202	213	525	171	267	191	239	251	621											
	MF 9000 DI	54 HP	1790	540	1800-1900	L-2	175	200	225	1833x28	190	226	144	226	162	202	213	525	171	267	191	239	251	621											
	PT-439	34 HP	1863	540	1800-1900	L-2	125	150	150	1833x28	190	226	144	226	162	202	213	525	171	267	191	239	251	621											
	PT-439	39 HP	1863	540	1800-1900	L-2	150	150	175	1833x28	190	226	144	226	162	202	213	525	171	267	191	239	251	621											
	PT-445	45 HP	1863	540	1800-1900	L-2	150	175	200	1833x28	190	226	144	226	162	202	213	525	171	267	191	239	251	621											
	PT-455	55 HP	1863	540	1800-1900	L-2	175	200	200	1833x28	NA	226	NA	NA	NA	NA	NA	NA	NA	NA	NA	171	267	191	239	251	621								
NEW HOLLAND	2522 DX	25 HP	1817	540	1800-1900	L-2	125	125	125	1833x28	190	226	144	226	162	202	213	525	171	267	191	239	251	621											
	4022	40 HP	2100	540	1800-1900	L-2	150	175	175	1833x28	190	226	144	226	162	202	213	525	171	267	191	239	251	621											
	4022 DX	50 HP	2000	540	1800-1900	L-2	175	200	200	1833x28	NA	226	NA	NA	NA	NA	NA	NA	NA	NA	171	267	191	239	251	621									
	6522	60 HP	2000	540	1800-1900	L-2	200	225	225	1833x28	NA	226	NA	NA	NA	NA	NA	NA	NA	NA	NA	171	267	191	239	251	621								
	3022	32 HP	1850	540	1800-1900	L-2	125	150	150	1833x28	190	226	144	226	162	202	213	525	171	267	191	239	251	621											
	3000 NX	35 HP	1850	540	1800-1900	L-2	125	150	150	1833x28	190	226	144	226	162	202	213	525	171	267	191	239	251	621											
SONALIKA	3037	37 HP	1850	540	1800-1900	L-2	150	150	175	1833x28	190	226	144	226	162	202	213	525	171	267	191	239	251	621											
	3130	40 HP	1850	540	1800-1900	L-2	150	175	175	1833x28	190	226	144	226	162	202	213	525	171	267	191	239	251	621											
	3230 NX	45 HP	1850	540	1800-1900	L-2	150	175	200	1833x28	190	226	144	226	162	202	213	525	171	267	191	239	251	621											
	4510	45 HP	1850	540	1800-1900	L-2	150	175	200	1833x28	190	226	144	226	162	202	213	525	171	267	191	239	251	621											
	3600 NX	50 HP	1850	540	1800-1900	L-2	175	200	200	1833x28	190	226	144	226	162	202	213	525	171	267	191	239	251	621											
	5600	55 HP	1850	540	1800-1900	L-2	200	200	200	1833x28	190	226	144	226	162	202	213	525	171	267	191	239	251	621											
D-730-II	6500	65 HP	1850	540	1800-1900	L-2	200	225	225	1833x28	190	226	144	226	162	202	213	525	171	267	191	239	251	621											
	DI-730-II	30 HP	1950	540	1800-1900	L-2	125	150	150	1833x28	190	226	144	226	162	202	213	525	171	267	191	239	251	621											
	DI-35	35 HP	1950	540	1800-1900	L-2	125	150	150	1833x28	190	226	144	226	162	202	213	525	171	267	191	239	251	621											
	DI-740-III S3	45 HP	1950	540	1800-1900	L-2	150	175	200	1833x28	190	226	144	226	162	202	213	525	171	267	191	239	251	621											
	DI-745-III	50 HP	1950	540	1800-1900	L-2	175	200	200	1833x28	190	226	144	226	162	202	213	525	171	267	191	239	251	621											
	DI-750-III	55 HP	1950	540	1800-1900	L-2	175	200	225	1833x28	190	226	144	226	162	202	213	525	171	267	191	239	251	621											

COMPATIBILITY CHART OF TRACTORS WITH ROTARY TILLER

DELIVERY CHECKLIST

Dealer Pre-Delivery (Please Tick)	Please Complete all Dealer information Below
<p>1. Dealer Pre-Delivery Checklist</p> <p>1. The customer or person responsible has been given the operator's manual.</p> <p>2. The customer undertakes to read the complete operator's manual and understands all aspects of the manual before operation of the machine.</p> <p>3. All safety, operational and maintenance information have been explained and demonstrated.</p> <p>4. All greasing and oil points, stickers, guarding and ID plate have been identified and physically pointed out.</p> <p>5. The customer agrees that it is his responsibility to read and carry out the safety, maintenance and operation as per this operator's manual.</p>	<p>Dealer Information</p> <p>Dealer's Name.....</p> <p>Address.....</p> <p>State..... Postcode.....</p> <p>Phone..... Fax.....</p> <p>Email.....</p> <p>Service Person.....</p> <p>I confirm that the pre-delivery service was performed on this machine.</p> <p>Signature.....</p> <p>Date.....</p> <p>Comments.....</p>
Customer Delivery (Please Tick)	Please Complete all Customer Information Below
<p>2. Customer Delivery Checklist</p> <p>1. The customer or person responsible has been given the operator's manual.</p> <p>2. The customer undertakes to read the complete operator's manual and understands all aspects of the manual before operation of the machine.</p> <p>3. All safety, operational and maintenance information have been explained and demonstrated.</p> <p>4. All greasing and oil points, stickers, guarding and ID plate have been identified and physically pointed out.</p> <p>5. The customer agrees that it is his responsibility to read and carry out the safety, maintenance and operation as per this operator's manual.</p>	<p>Customer Information</p> <p>Customer's Name.....</p> <p>Address.....</p> <p>State..... Postcode.....</p> <p>Phone..... Fax.....</p> <p>Email.....</p> <p>Delivery Person.....</p> <p>I confirm that all of the delivery checks were explained and performed.</p> <p>Signature.....</p> <p>Delivery Date.....</p> <p>Comments.....</p>

FIELDKING

WARRANTY CARD Customer Copy

CUSTOMER NAME Mr./ Mrs :

ADDRESS :

MOBILE NO. :

Email :

NAME OF IMPLEMENT :

MODEL NO. :

YEAR OF Mfg. :

SERIAL NO. :

REGISTRATION NO. :

DATE OF PURCHASING :

NAME OF DEALER :

Customer's Signature

Dealer's Signature



Beru Udyog Pvt. Ltd.

Corporate Office : Plot No. 235-236 & 238-240, Sec-3, HSIIDC,
 Karnal- 132001 (Haryana), India ☎ +91-184-2221571/ 72/ 73
 ✉ marketing@fieldking.com, exports@fieldking.com, 🌐 www.fieldking.com

FIELDKING

WARRANTY CARD Company Copy

CUSTOMER NAME Mr./ Mrs :

ADDRESS :

MOBILE NO. :

Email :

NAME OF IMPLEMENT :

MODEL NO. :

YEAR OF Mfg. :

SERIAL NO. :

REGISTRATION NO. :

DATE OF PURCHASING :

NAME OF DEALER :

Customer's Signature

Dealer's Signature

  **Beri Udyog Pvt. Ltd.**

Corporate Office : Plot No. 235-236 & 238-240, Sec-3, HSIIDC,
Karnal- 132001 (Haryana), India 📞 +91-184-2221571/ 72/ 73
✉️ marketing@fieldking.com, exports@fieldking.com, 🌐 www.fieldking.com

FIELDKING

WARRANTY CARD

Dealer Copy

CUSTOMER NAME Mr./ Mrs :

ADDRESS :

MOBILE NO. :

Email :

NAME OF IMPLEMENT :

MODEL NO. :

YEAR OF Mfg. :

SERIAL NO. :

REGISTRATION NO. :

DATE OF PURCHASING :

NAME OF DEALER :

Customer's Signature

Dealer's Signature

  **Beri Udyog Pvt. Ltd.**

Corporate Office : Plot No. 235-236 & 238-240, Sec-3, HSIIDC,
Karnal- 132001 (Haryana), India 📞 +91-184-2221571/ 72/ 73
✉️ marketing@fieldking.com, exports@fieldking.com, 🌐 www.fieldking.com